

EL-O-Matic

Rack and Pinion Pneumatic Actuators

- High quality and economical actuator
- Improve plant and operator safety
- Reliable and flexible in process control
- Increase serviceability

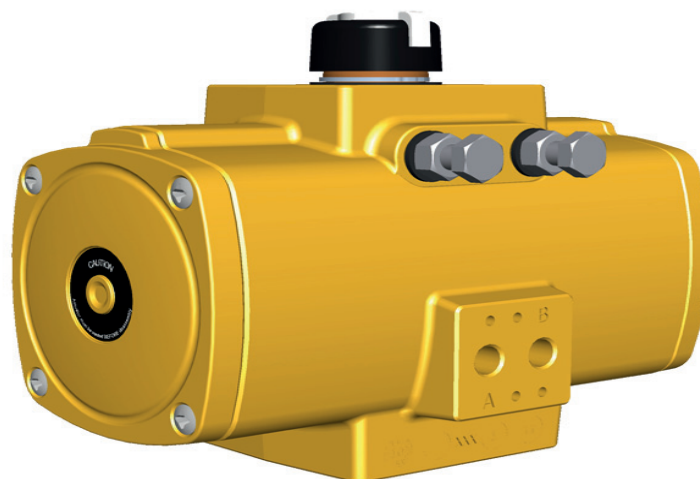

Table of Contents

Section 1: General

General Specifications	4
Construction, Parts and Materials.....	6
EL-O-Matic F Corrosion Protection System.....	7
Assembly codes EL-O-Matic F actuators.....	8

Section 2: Product Configuration Code

Product configuration code.....	9
---------------------------------	---

Section 3: Torque

Actuator Torque - Spring Return (Nm)	10
Actuator Torque - Spring Return (Nm)	11
Actuator Torque - Spring Return (lbf.in)	12
Actuator Torque - Spring Return (lbf.in)	13
Actuator Torque - Double Acting (Nm)	14
Actuator Torque - Double Acting (lbf.in)	15
Sizing of Rack & Pinion actuators	16
Spring cartridge placement.....	18

Section 4: Dimensions

Dimensions - Metric F12 (ISO5211)	19
Dimensions - Imperial F12 (ISO5211)	20
Dimensions - Metric F12 (DIN3337).....	21
Dimensions - Metric (ISO5211).....	22
Dimensions - Metric (ISO5211).....	23
Dimensions - Metric (DIN3337)	24
Dimensions - Metric (DIN3337)	25
Dimensions - Imperial (ISO5211).....	26
Dimensions - Imperial (ISO5211).....	27

Section 5: Integral Options

Drive Inserts	28
Center Plate.....	29
Visual indicator EL-O-Matic F series actuators	30
CSR Coating + Chemical Resistance List for CSR Coating.....	31
High Temperature Execution	32
Low Temperature Execution	33

General Specifications

Torque Range

- 354 to 13417.2 lbf.in (40 to 1600 Nm)

Pressure Range

- Double Acting:
 - 2.9 to 120 psig (0.2 to 8.3 barg)
- Spring Return:
 - 87 to 120 psig (6 to 8.3 barg), with maximum spring set
 - 43.5 to 120 psig (3 to 8.3 barg), reduced spring quantity

Pressure Media

- Air, dry or lubricated and inert gases
- Dew point at least 10K below ambient temperature.
- For sub-zero applications, take appropriate measures
- Mentioned pressure levels are "gauge pressures". Gauge pressure is equal to absolute pressure minus atmospheric pressure.

Finish

- Body: Anodized
- End caps: Polyurethane powder coated
- Pistons: Chromated
- Pinion: Zinc plated / yellow chromated
- Fasteners: Stainless steel

Lubrication

- Castrol High Temperature grease (or equivalent)

Temperature Range

- Standard: -4 to 175°F (-20°C to 80°C)
- Option:
 - Low temperature: -40°F to 176°F (-40°C to 80°C)
 - High temperature: -20°F to 248°F (-20°C to 120°C)

Angle of Rotation

- Factory set at 90°
- Adjustable range:
 - Size 25 to 600: -5° to +10° and +80° to 95°
 - Size 950 to 4000: -3° to +10° and +80° to 93°

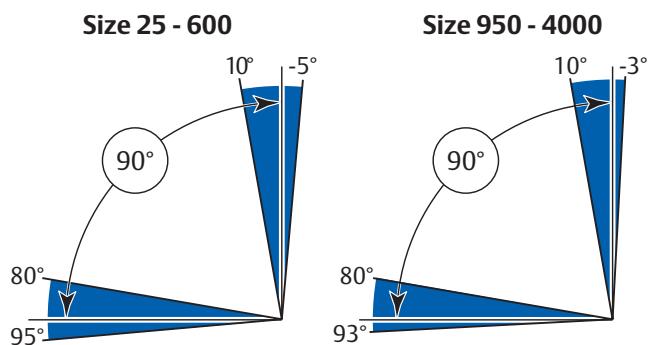

Angle of Rotation

Compliance to International Standards

- Valve flange: ISO 5211/DIN3337
- Solenoid flange: VDE/VDI 3845 (NAMUR)
- Accessory flange: VDE/VDI 3845 (NAMUR)
- European Directives: ATEX, PED and Machinery Directive

Actuator Weight

Actuator Model	Double Acting		Spring Return Springset N=6	
	lbs	(kg)	lbs	(kg)
F 12	1.3	0.6	1.5	0.7
F 25	3.1	1.4	3.5	1.6
F 40	4.6	2.1	5.1	2.3
F 65	6.2	2.8	7.3	3.3
F 100	7.7	3.5	9.5	4.3
F 150	10.8	4.9	14.6	6.6
F 200	13.2	6.0	18.3	8.3
F 350	22	10.2	32	14.5
F 600	44	20	62	28
F 950	60	27	86	39
F 1600	95	43	146	66
F 2500	126	57	194	88
F 4000	192	87	291	132

Operating Speed

Actuator Model	Cycle time in seconds			
	Spring Return		Double acting	
	Opening Stroke	Closing Stroke	Opening Stroke	Closing Stroke
F 12	0.4	0.4	0.4	0.4
F 25	0.5	0.4	0.5	0.4
F 40	0.6	0.5	0.6	0.5
F 65	0.7	0.5	0.6	0.6
F 100	0.8	0.6	0.8	0.7
F 150	1.0	0.8	0.9	0.8
F 200	1.3	0.9	1.0	1.0
F 350	1.9	1.3	1.4	1.5
F 600	3.2	1.9	2.2	2.2
F 950	4.6	3.2	3.9	3.6
F 1600	6.9	4.8	5.9	4.8
F 2500	9.0	6.3	7.8	7.9
F 4000	15.4	10.8	13.3	13.0

Test conditions:

1. Solenoid with flow capacity: 0.6 m3/hr
2. Pipe diameter: 6mm
3. Medium: clean air
4. Supply pressure: 5.5 bar
5. Load: with average load
6. Stroke: 90°
7. Temperature: Room temperature

Actuator air volumes and consumption

Actuator model	Actuator volumes:		
	Maximum volume (in liters)		
	Central ¹ chamber	End cap ² chamber	Displace ³ volume
F0012	0.05	0.06	0.04
F0025	0.11	0.19	0.08
F0040	0.16	0.36	0.15
F0065	0.36	0.55	0.22
F0100	0.4	0.8	0.3
F0150	0.8	0.7	0.5
F0200	0.8	1.0	0.7
F0350	1.9	1.7	1.2
F0600	3.1	2.9	2.1
F0950	5.1	4.3	3.2
F1600	7.8	7.0	5.2
F2500	10.4	11.1	8.2
F4000	18.4	18.9	14.0

Consumption per stroke (in liters, pressure in Bar)					
Outward Stroke			Inward Stroke		
Double acting and Spring Return			Double acting only		
2	4	8	2	4	8
0.29	0.50	0.9	0.46	0.85	1.6
0.29	0.50	0.9	0.46	0.85	1.6
0.47	0.8	1.5	0.87	1.6	3.0
0.9	1.6	3.1	1.3	2.4	4.6
1.0	1.7	3.2	2.0	3.6	6.9
2.1	3.6	6.8	1.9	3.4	6.2
2.4	4.0	7.3	2.7	4.6	8
5.1	9	17	5	8	15
8	14	27	8	14	25
13	23	44	12	20	37
21	36	68	19	33	62
29	50	92	30	53	97
51	87	161	52	89	165

Actuator model	Actuator volumes:		
	Maximum volume (in liters)		
	Central ¹ chamber	End cap ² chamber	Displace ³ volume
F0012	3.1	3.7	2.5
F0025	6.4	11.8	4.7
F0040	10.0	22	8.9
F0065	22	34	13.5
F0100	22	50	19.9
F0150	48	43	32
F0200	50	59	44
F0350	118	103	76
F0600	189	174	129
F0950	310	260	193
F1600	477	430	319
F2500	638	676	501
F4000	1122	1151	853

Consumption per stroke (in liters, pressure in Bar)					
Outward Stroke			Inward Stroke		
Double acting and Spring Return			Double acting only		
2	4	8	2	4	8
23	40	56	37	70	99
23	40	56	37	70	99
36	64	89	70	131	186
74	134	188	107	200	283
80	140	194	158	295	419
163	295	413	151	270	377
182	320	444	207	369	516
402	729	1022	359	642	896
650	1171	1640	610	1091	1523
1049	1905	2675	910	1628	2274
1635	2951	4135	1505	2691	3759
2259	4018	5600	2367	4232	5911
3946	7040	9825	4027	7202	10059

Notes:

1. For Double acting and Spring Return. Pistons at 90° outward position
2. Only for Double acting. Pistons at 0° inward position
3. Stroke is 90°

Central air chamber volume
Double acting and Spring Return

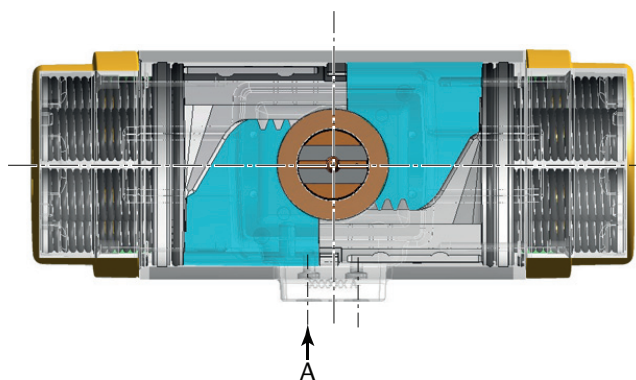

End cap air chamber volume
Double acting only

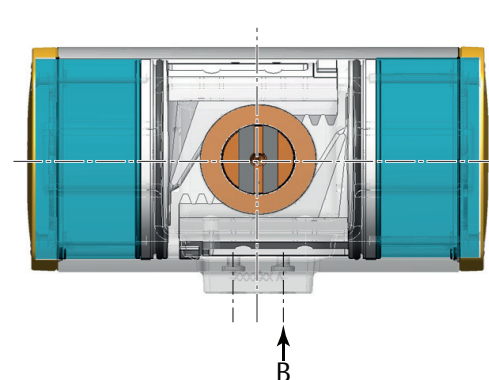

Construction, Parts and Materials

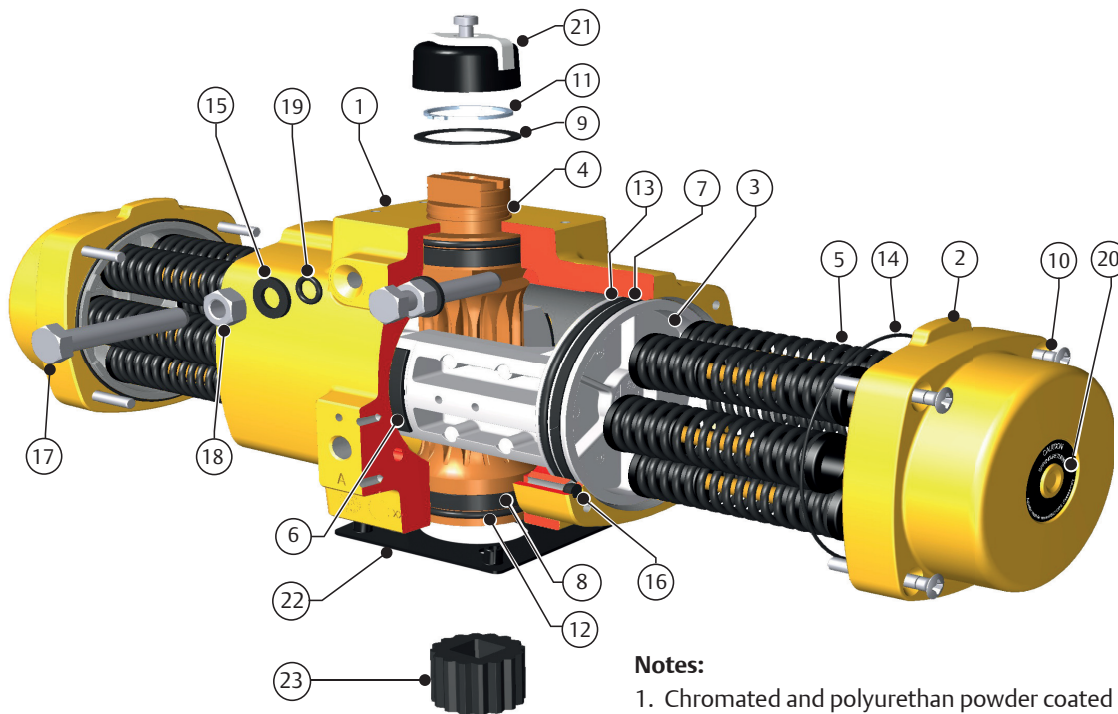

Notes:

1. Chromated and polyurethan powder coated
2. Chromated and polyurethan powder coated
3. Hard anodized
4. Electrophoretic coated
5. Deltatone® coated

Pos.	Qty	Description	Material	Notes
1	1	House	Cast Aluminium alloy	1
2	2	End cap	Cast Aluminium alloy	2
3	2	Piston	Cast Aluminium alloy	
4	1	Pinion	High grade aluminium	3
5	Max. 12	Spring cartridge	Spring steel	4
6	2	Bearing strip piston rack	POM	
7	2	Bearing piston	PTFE 25% carbon filled	
8	2	Bearing pinion	POM	
9	1	Thrust washer	POM, black UV stabilized	
10	8	End cap screw	Stainless Steel	
11	1	Circlip	Spring steel	5
12	2	O-ring seal pinion	Nitrile rubber	
13	2	O-ring seal piston	Nitrile rubber	
14	2	O-ring seal end cap	Nitrile rubber	
15	2	O-ring seal limit stop	Nitrile rubber	
16	2	B-port seal	Silicon rubber	
17	2	Limit stop screw	Stainless steel	
18	2	Limit stop nut	Stainless steel	
19	2	Limit stop washer	PA66	
20	2	Warning sticker	Polyester	
21	1	Indicator assembly	ABS + stainless steel screw	
22	1	Center plate (option)	Nylon PA6, Black	
23	1	Insert drive	Aluminium alloy	

* = Included in repair kit

EL-O-Matic F Corrosion Protection System

Description

The corrosion protection system of standard EL-O-Matic F series pneumatic actuators consist of the following treatments or materials:

Pre-treatment

The housing and end caps get a chromate pre-treatment prior to painting. The pre-treatment takes care of a perfect bonding of the paint layer to the aluminium housing and gives additional corrosion protection to the bore of the housing.

Powder coat

- Polyurethane powder coating for exterior use.
- The powder coating is applied cold using automatic electrostatic spray equipment and is cured for about 10 minutes at minimum 200°C (392°F) offering excellent light and weather resistance.
- The powder coating thickness is between 80 and 160 microns (3.15 and 6.3 mils) .
- Good chemical resistance against most bases, acids, solvents, alkalis and oils at normal temperatures.
- Excellent exterior mechanical durability.
- The coating has passed a salt spray test according to ASTM B117 for 500 hours.

The powder coating is virtually solvent free, and therefore environmentally friendly.

High grade & hard anodized aluminium pinion

Actuators with high grade & hard anodized aluminium pinions, passed a 500 hours salt spray test. Optional stainless steel pinions are available for a higher corrosion resistance.

Stainless steel or Deltatone treated external steel parts

External parts are stainless steel or steel alloy with a Deltatone® treatment for optimum protection and durability.

The chemical and durability assessment.

All these components, treatments and finishes, including the durable pinion design, anodized surface finish, standard powder coat paint and Stainless steel treated external fasteners shows no decline of actuator functions after 500 hours salt spray test.

Technical Data

Coating :	Polyurethane powder coating for exterior use.
Salt spray test :	ASTM B117: 500 hours
Color :	Yellow (RAL 1007)
Materials: Housing:	Anodized Aluminium alloy
Pinion:	High grade aluminium alloy, hard anodized (Option: Stainless steel)
Fasteners:	Stainless steel or alloy steel with Deltatone® treatment
Type Sticker:	Nylon
Application:	Standard EL-O-Matic F series pneumatic actuators
Option:	CSR coating for excellent corrosion resistance. See data sheet EFG.05.04. EN

Table 1. Test result polyurethane powder coating

No	Item	Standard	Specification
1	Hardness	ASTM D3363 Pencil (Mitsubishi Uni)	2H
2	Adhesion	ISO 2409, ASTM D3359 Cross hatch test (2mm)	Gt (0) 100% Adhesion
3	Impact test	ASTM D2794 5/8" Ball (direct)	Min. 25 lb.in without detachment
4	Bend test	DIN 53152, ISO1519, ASTM D522	Min 5 mm without cracking
5	Acid resistance	ISO 2512 5% H2SO4, 1 Hour	No Blistering
6	Alkali resistance	ISO 2812 5% Na CO3, 1 hour	No Blistering
7	Water resistance	20° C, 7 days	No Blistering
8	Boiling test	1 hour @ 98°C	No Blistering

1. This data sheet contains general information as supplied by the paint supplier and describes typical properties for the coating.

Assembly codes EL-O-Matic F actuators

Spring return actuators

Assembly code: CW

= Standard, Clock Wise-to-Close rotation

= Fail-to-Close

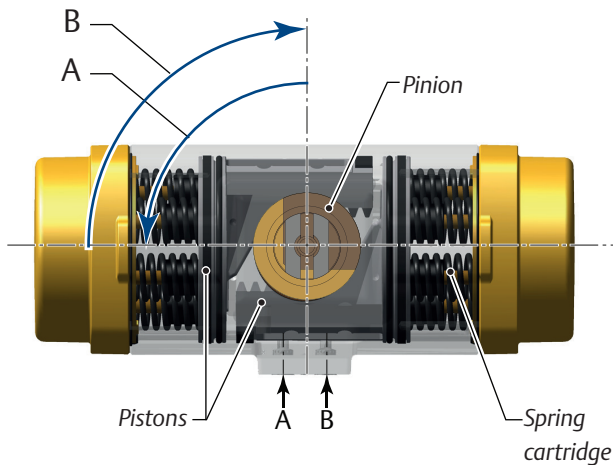

Assembly code: CC

= Reverse, Counter Clock Wise-to-Open

= Fail-to-Open

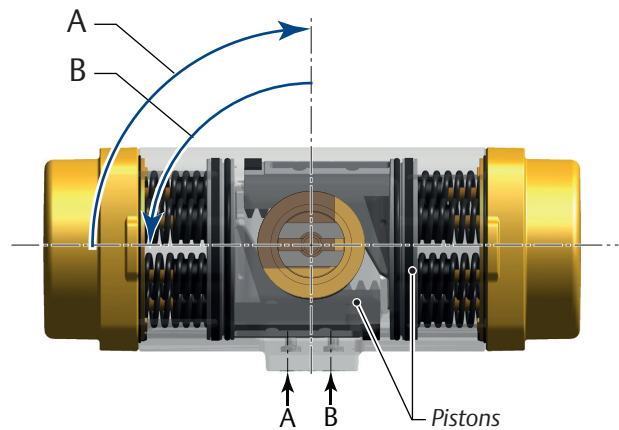

A = Central air chamber pressurized
B = Spring stroke

Double acting actuators

Assembly code: CW

= Standard, Clock Wise-to-Close rotation

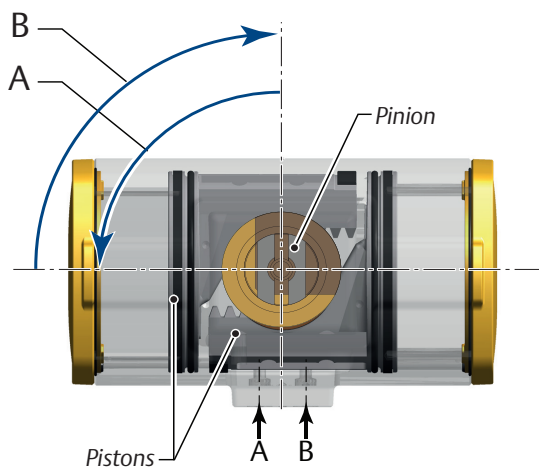

Assembly code: CC

= Reverse, Counter Clock Wise-to-Open

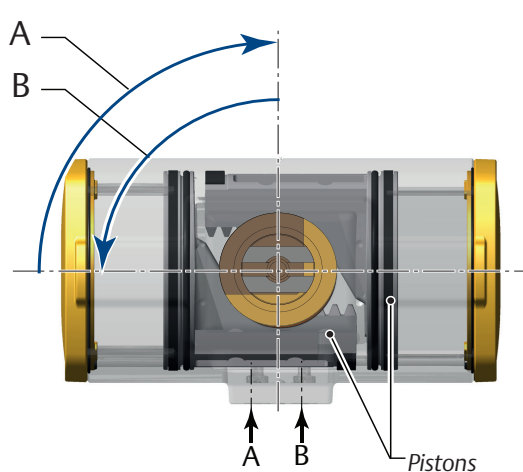

A = Central air chamber pressurized
B = End cap air chambers pressurized

All views are from above. Pistons are shown in inward position.

Product configuration code

FS 0150 U 40 CW AL T NL17 S K A 00 XX

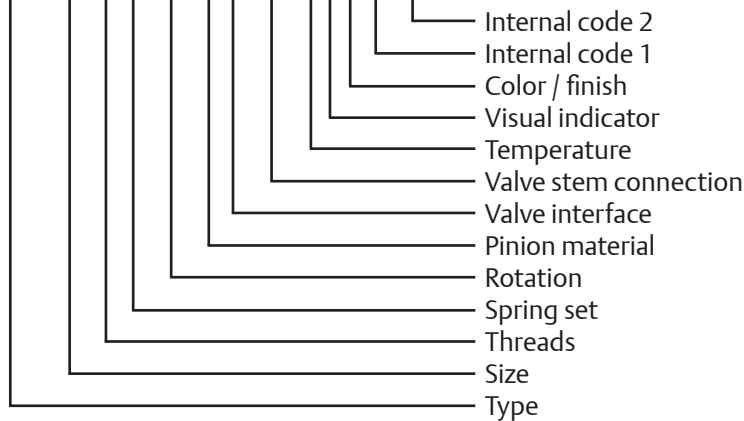

Type:	
FD	Double acting
FS	Spring return

Size:	
Body sizes: 0012, 0025, 0040, 0065, 0100, 0150, 0200, 0350, 0600, 0950, 1600, 2500 and 4000	

Threads:	
M	Metric - ISO 5211.
U	Imperial - ISO 5211 (UNC/NPT).

Spring set:	
00	For double acting (no springs)
10, 20, 30, 40, 50 or 60	For spring return

Rotation:	
CW	Spring to Close / Clock Wise
CC	Spring to Open / Counter Clock Wise

Pinion material:	
AL	Aluminium, hard anodized.

Valve Interface:	
T	Standard ISO 5211 - interface
S	Small interface with center plate DIN 3337
L	Large interface with center plate DIN 3337

Valve Stem connection (Insert Sizes):	
0000	No Insert

Parallel drive: □	Diagonal drive : ◇	Square:	Actuator size(s):
NL11	YD11	11mm / 0.433"	0025
NL14	YD14	14mm / 0.551"	0040 & 0065
NL19	YD17	17mm / 0.669" 19mm / 0.748"	0100 & 0150
NL22	YD22	22mm / 0.866"	0200
NL27	YD22	22mm / 0.866" 27mm / 1.063"	0350
NL27	YD27	27mm / 1.063"	0600
NL36	YD36	36mm / 1.417"	0950
NL46	YD46	46mm / 1.811"	1600 & 2500
NL55	YD55	55mm / 2.165"	4000

See data sheet EFG.05.01.EN for a more detailed overview of available inserts.

Drive insert designation is according ISO 5211.

Temperature Ranges:		
S	Standard:	-20°C to +80°C (-4°F to +176°F)
H	High Temperature:	-20°C to +120°C (-4°F to +248°F)
L	Low Temperature	-40°C to +80°C (-40°F to +176°F)

Visual indicator:	
K	Standard (knob style)
N	No Visual indicator

Finish:	
A	Standard coating
C	CSR coating

Note: CSR coating not available for Size 2500 and 4000

Internal code 1:	
00	Standard

Internal code 2:	
XX	Standard

Actuator Torque - Spring Return (Nm)

Actuator Size	Spring set nr.	Spring Stroke Torque (Nm)		Air Torque (Nm)																	
				SUPPLY PRESSURE																	
				3.0 barg		3.5 barg		4.0 barg		4.5 barg		5.0 barg		5.5 barg		6.0 barg		7.0 barg		8.0 barg	
		Start	End	Start	End	Start	End	Start	End	Start	End	Start	End	Start	End	Start	End	Start	End	Start	End
FS 12	20	7	5	2	-1	4	1	5	2	6	3	8	5	9	6	10	7	13	10	15	12
FS 25	10	4	2	12	10	14	13	17	15	19	17	21	20	24	22	26	25	31	29	36	34
	20	7	4	9	6	12	9	14	11	16	13	19	16	21	18	24	21	28	25	33	30
	30	11	7	7	2	9	4	11	7	14	9	16	12	19	14	21	17	26	21	31	26
	40	14	9	-	-	-	-	9	3	11	5	14	8	16	10	18	12	23	17	28	22
	50	18	11	-	-	-	-	-	-	9	1	11	4	14	6	16	8	21	13	26	18
	60	21	13	-	-	-	-	-	-	-	-	-	-	11	2	13	4	18	9	23	14
FS 40	10	7	4	22	19	26	24	31	28	36	33	40	37	45	42	49	46	58	55	67	64
	20	13	8	17	12	22	16	26	21	31	25	35	30	40	34	44	39	53	48	62	57
	30	20	12	12	4	17	9	21	13	26	18	31	22	35	27	40	31	49	40	58	49
	40	26	17	-	-	12	1	17	6	21	10	26	15	30	19	35	24	44	33	53	42
	50	33	21	-	-	-	-	-	-	17	3	21	7	26	12	30	16	39	25	48	34
	60	39	25	-	-	-	-	-	-	-	-	-	-	21	4	25	9	34	18	43	27
FS 65	10	10	6	33	29	40	36	47	43	54	50	61	57	68	63	75	70	88	84	102	98
	20	20	13	26	17	33	24	40	31	47	38	53	45	60	52	67	59	81	72	95	86
	30	31	19	19	5	25	12	32	19	39	26	46	33	53	40	60	47	74	61	87	74
	40	41	26	-	-	-	-	25	8	32	14	39	21	46	28	52	35	66	49	80	63
	50	51	32	-	-	-	-	-	-	24	3	31	10	38	17	45	23	59	37	73	51
	60	61	39	-	-	-	-	-	-	-	-	-	-	31	5	38	12	52	25	65	39
FS 100	10	15	9	49	43	60	53	70	64	80	74	90	84	100	94	111	104	131	125	151	145
	20	30	19	39	26	49	36	59	47	69	57	79	67	90	77	100	87	120	108	141	128
	30	44	28	28	9	38	19	48	30	59	40	69	50	79	60	89	70	109	91	130	111
	40	59	37	-	-	27	2	38	13	48	23	58	33	68	43	78	53	99	74	119	94
	50	74	47	-	-	-	-	-	-	37	6	47	16	57	26	68	36	88	57	108	77
	60	89	56	-	-	-	-	-	-	-	-	-	-	47	9	57	19	77	40	98	60
FS 150	10	24	15	79	69	96	86	112	102	128	118	145	135	161	151	177	167	210	200	243	233
	20	47	30	62	42	79	59	95	75	111	91	128	108	144	124	160	140	193	173	226	206
	30	71	44	45	15	62	32	78	48	94	64	111	81	127	97	143	113	176	146	209	179
	40	94	59	-	-	45	5	61	21	77	37	94	54	110	70	126	86	159	119	192	152
	50	118	74	-	-	-	-	-	-	60	10	77	26	93	43	109	59	142	92	175	124
	60	141	89	-	-	-	-	-	-	-	-	-	-	76	16	92	32	125	65	158	97
FS 200	10	33	21	108	94	131	117	153	139	175	161	198	184	220	206	242	228	287	273	332	318
	20	65	41	85	57	107	79	129	102	152	124	174	146	196	169	219	191	263	236	308	280
	30	98	62	61	19	83	42	106	64	128	86	150	109	173	131	195	153	240	198	284	243
	40	131	82	-	-	-	-	82	26	104	49	127	71	149	93	171	116	216	161	261	205
	50	163	103	-	-	-	-	-	-	81	11	103	34	125	56	148	78	192	123	237	168
	60	196	124	-	-	-	-	-	-	-	-	-	-	102	18	124	41	169	85	213	130
FS 350	10	56	35	189	165	227	204	266	243	305	281	344	320	383	359	422	398	499	476	577	553
	20	112	70	148	101	187	139	226	178	265	217	303	256	342	295	381	334	459	411	537	489
	30	168	106	108	36	146	75	185	114	224	153	263	192	302	231	341	269	418	347	496	425
	40	224	141	-	-	106	11	145	50	184	89	222	127	261	166	300	205	378	283	455	360
	50	280	176	-	-	-	-	-	-	143	24	182	63	221	102	260	141	337	218	415	296
	60	335	211	-	-	-	-	-	-	-	-	-	-	180	38	219	77	297	154	374	232
FS 600	10	96	60	320	279	386	345	452	411	518	477	584	543	650	609	716	675	848	807	980	939
	20	192	121	251	169	317	235	383	301	449	367	515	433	581	499	647	565	779	697	911	829
	30	287	181	181	59	247	125	313	191	379	257	445	323	511	389	577	455	709	587	841	719
	40	383	241	-	-	178	15	244	81	310	147	376	213	442	279	508	345	640	477	772	609
	50	479	302	-	-	-	-	-	-	241	37	307	103	373	169	439	235	571	367	703	499
	60	575	362	-	-	-	-	-	-	-	-	-	-	303	59	369	125	501	257	633	389

Actuator Torque - Spring Return (Nm)

Actuator Size	Spring set nr.	Spring Stroke Torque (Nm)		Air Torque (Nm)																	
				SUPPLY PRESSURE																	
		3.0 barg	3.5 barg	4.0 barg	4.5 barg	5.0 barg	5.5 barg	6.0 barg	7.0 barg	8.0 barg	Start	End	Start	End	Start	End	Start	End	Start	End	Start
FS 950	10	150	95	496	432	598	534	701	637	803	739	906	842	1008	944	1110	1047	1315	1251	1520	1456
	20	300	189	387	259	490	362	592	464	694	567	797	669	899	772	1002	874	1207	1079	1412	1284
	30	450	284	278	87	381	189	483	292	586	394	688	497	791	599	893	702	1098	907	1303	1111
	40	600	378	-	-	-	-	375	119	477	222	580	324	682	427	784	529	989	734	1194	939
	50	750	473	-	-	-	-	-	-	368	49	471	152	573	254	676	357	881	562	1086	767
	60	900	567	-	-	-	-	-	-	-	-	-	-	465	82	567	184	772	389	977	594
FS 1600	10	246	155	811	707	979	875	1147	1042	1314	1210	1482	1377	1650	1545	1817	1713	2153	2048	2488	2383
	20	491	309	634	425	801	592	969	760	1136	928	1304	1095	1472	1263	1639	1431	1975	1766	2310	2101
	30	737	464	456	142	623	310	791	478	959	645	1126	813	1294	981	1462	1148	1797	1484	2132	1819
	40	982	619	-	-	-	-	613	195	781	363	948	531	1116	698	1284	866	1619	1201	1954	1537
	50	1228	773	-	-	-	-	-	-	603	81	771	249	938	416	1106	584	1441	919	1777	1254
	60	1473	928	-	-	-	-	-	-	-	-	-	-	761	134	928	302	1263	637	1599	972
FS 2500	10	396	249	1308	1140	1578	1410	1848	1680	2119	1950	2389	2221	2659	2491	2929	2761	3470	3302	4010	3842
	20	792	499	1021	685	1292	955	1562	1225	1832	1495	2102	1766	2373	2036	2643	2306	3183	2847	3724	3387
	30	1187	748	735	230	1005	500	1275	770	1545	1040	1816	1311	2086	1581	2356	1851	2897	2392	3437	2932
	40	1583	997	-	-	-	-	988	315	1259	585	1529	856	1799	1126	2070	1396	2610	1937	3151	2477
	50	1979	1247	-	-	-	-	-	-	972	130	1242	401	1513	671	1783	941	2323	1482	2864	2022
	60	2375	1496	-	-	-	-	-	-	-	-	-	-	1226	216	1496	486	2037	1027	2577	1567
FS 4000	10	633	399	2093	1823	2525	2256	2958	2688	3390	3121	3822	3553	4255	3986	4687	4418	5552	5283	6417	6148
	20	1267	798	1634	1095	2067	1528	2499	1960	2931	2393	3364	2825	3796	3258	4229	3690	5094	4555	5958	5420
	30	1900	1197	1175	367	1608	800	2040	1232	2473	1665	2905	2097	3338	2530	3770	2962	4635	3827	5500	4692
	40	2533	1596	-	-	-	-	1582	504	2014	937	2447	1369	2879	1802	3311	2234	4176	3099	5041	3964
	50	3167	1995	-	-	-	-	-	-	1555	209	1988	641	2420	1074	2853	1506	3718	2371	4583	3236
	60	3800	2394	-	-	-	-	-	-	-	-	-	-	1962	346	2394	778	3259	1643	4124	2508

Note:

1. Emerson Process Management recommends that the valve manufacturer supply the maximum required torque values (Including any adjustments or suggested safety factors for valve service conditions or application).
2. Additionally, the valve manufacturer must identify at which position(s) and direction(s) of rotation (Counter Clock Wise or Clock Wise) these maximum requirements occur.
3. If in doubt, or you require any assistance with sizing actuators, do not hesitate to contact your nearest Emerson's Valve Automation Division representative.

Figure 1. Spring Return torque diagram

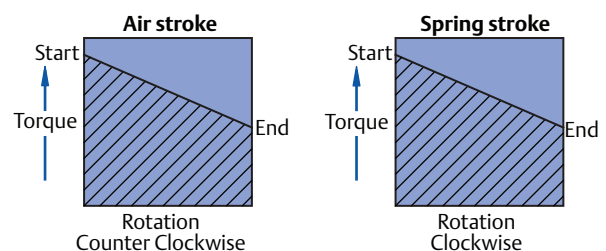

Actuator Torque - Spring Return (lbf.in)

Actuator Size	Spring set nr.	Spring Stroke Torque (lbf.in)		Air Torque (lbf.in)															
				SUPPLY PRESSURE															
		40 psig		50 psig		60 psig		70 psig		80 psig		90 psig		100 psig		120 psig			
Start	End	Start	End	Start	End	Start	End	Start	End	Start	End	Start	End	Start	End	Start	End		
FS 12	20	64	41	15	-11	31	5	47	21	63	37	79	53	95	69	111	84	142	116
FS 25	10	31	20	93	80	123	109	152	139	181	168	211	198	240	227	270	257	329	316
	20	63	39	70	44	100	73	129	103	159	132	188	162	218	191	247	221	306	280
	30	94	59	48	8	77	37	107	67	136	96	166	126	195	155	225	185	283	244
	40	125	79	25	-28	55	1	84	31	113	60	143	90	172	119	202	149	261	208
	50	156	99	2	-64	32	-34	61	-5	91	24	120	54	150	83	179	113	238	172
	60	188	118	-20	-100	9	-70	39	-41	68	-11	98	18	127	47	157	77	216	136
FS 40	10	58	37	175	150	230	206	285	261	341	316	396	371	451	427	506	482	617	592
	20	116	73	133	84	188	139	243	195	299	250	354	305	409	360	464	415	575	526
	30	174	110	91	18	146	73	201	128	257	183	312	239	367	294	422	349	533	459
	40	231	146	49	-49	104	6	159	62	214	117	270	172	325	227	380	283	491	393
	50	289	183	7	-115	62	-60	117	-5	172	50	228	106	283	161	338	216	449	327
	60	347	220	-35	-182	20	-127	75	-71	130	-16	186	39	241	94	296	150	407	260
FS 65	10	90	57	265	227	349	311	434	395	518	479	602	564	686	648	770	732	939	900
	20	181	114	200	123	284	207	368	291	452	376	537	460	621	544	705	628	873	796
	30	271	171	134	19	219	103	303	188	387	272	471	356	555	440	639	524	808	693
	40	361	228	69	-85	153	0	237	84	322	168	406	252	490	336	574	420	742	589
	50	452	285	4	-189	88	-104	172	-20	256	64	340	148	424	232	509	317	677	485
	60	542	341	-62	-292	22	-208	106	-124	191	-40	275	44	359	129	443	213	612	381
FS 100	10	131	83	394	339	518	463	643	588	767	712	892	836	1016	961	1141	1085	1390	1334
	20	262	166	299	188	423	313	548	437	672	562	797	686	921	811	1046	935	1295	1184
	30	392	248	203	38	328	162	452	287	577	411	701	536	826	660	950	785	1199	1034
	40	523	331	108	-113	233	12	357	136	482	261	606	385	731	510	855	634	1104	883
	50	654	414	13	-263	138	-138	262	-14	387	110	511	235	636	359	760	484	1009	733
	60	785	497	-82	-413	42	-289	167	-164	291	-40	416	85	540	209	665	334	914	583
FS 150	10	208	131	633	544	832	743	1031	942	1231	1142	1430	1341	1629	1540	1829	1740	2227	2138
	20	416	262	482	304	681	504	881	703	1080	902	1279	1102	1479	1301	1678	1500	2077	1899
	30	625	393	332	65	531	264	730	464	930	663	1129	862	1328	1062	1528	1261	1926	1660
	40	833	524	181	-174	381	25	580	224	779	424	979	623	1178	823	1377	1022	1776	1421
	50	1041	654	31	-414	230	-214	429	-15	629	185	828	384	1027	583	1227	783	1626	1181
	60	1249	785	-120	-653	80	-454	279	-254	478	-55	678	145	877	344	1076	543	1475	942
FS 200	10	289	182	862	739	1135	1012	1408	1285	1681	1558	1954	1831	2226	2104	2499	2376	3045	2922
	20	578	364	653	407	926	680	1198	953	1471	1226	1744	1499	2017	1771	2290	2044	2836	2590
	30	867	547	443	75	716	348	989	621	1262	894	1535	1166	1808	1439	2080	1712	2626	2258
	40	1156	729	234	-257	507	16	780	289	1052	561	1325	834	1598	1107	1871	1380	2417	1926
	50	1445	911	24	-589	297	-317	570	-44	843	229	1116	502	1389	775	1662	1048	2207	1593
	60	1734	1093	-185	-922	88	-649	361	-376	634	-103	906	170	1179	443	1452	716	1998	1261
FS 350	10	495	312	1503	1293	1978	1767	2452	2241	2926	2716	3400	3190	3874	3664	4348	4138	5296	5086
	20	990	624	1145	724	1619	1199	2093	1673	2567	2147	3041	2621	3515	3095	3990	3569	4938	4517
	30	1485	936	786	156	1261	630	1735	1104	2209	1578	2683	2052	3157	2526	3631	3000	4579	3948
	40	1979	1248	428	-413	902	61	1376	535	1850	1009	2324	1483	2798	1957	3272	2431	4221	3380
	50	2474	1560	69	-982	543	-508	1018	-34	1492	440	1966	914	2440	1388	2914	1863	3862	2811
	60	2969	1872	-289	-1551	185	-1077	659	-603	1133	-129	1607	346	2081	820	2555	1294	3504	2242
FS 600	10	848	534	2551	2190	3356	2996	4162	3801	4968	4607	5773	5413	6579	6218	7385	7024	8996	8635
	20	1695	1068	1937	1216	2743	2021	3548	2827	4354	3633	5160	4438	5965	5244	6771	6050	8382	7661
	30	2543	1601	1324	241	2129	1047	2935	1853	3741	2658	4546	3464	5352	4270	6158	5075	7769	6687
	40	3391	2135	710	-733	1516	73	2321	878	3127	1684	3933	2490	4738	3295	5544	4101	7155	5712
	50	4238	2669	96	-1707	902	-902	1708	-96	2513	710	3319	1515	4125	2321	4930	3127	6542	4738
	60	5086	3203	-517	-2682	289	-1876	1094	-1071	1900	-265	2706	541	3511	1346	4317	2152	5928	3763

Actuator Torque - Spring Return (lbf.in)

Actuator Size	Spring set nr.	Spring Stroke Torque (lbf.in)		Air Torque (lbf.in)															
				SUPPLY PRESSURE															
		Start	End	40 psig		50 psig		60 psig		70 psig		80 psig		90 psig		100 psig		120 psig	
FS 950	10	1328	837	3950	3385	5200	4635	6451	5886	7701	7136	8952	8387	10202	9637	11453	10888	13954	13389
	20	2656	1673	2988	1859	4239	3109	5489	4360	6740	5610	7990	6861	9241	8111	10491	9362	12992	11863
	30	3983	2510	2027	333	3277	1583	4528	2834	5778	4084	7029	5334	8279	6585	9530	7835	12030	10336
	40	5311	3346	1065	-1194	2316	57	3566	1307	4817	2558	6067	3808	7318	5059	8568	6309	11069	8810
	50	6639	4183	104	-2720	1354	-1469	2605	-219	3855	1032	5106	2282	6356	3532	7606	4783	10107	7284
	60	7967	5019	-858	-4246	393	-2996	1643	-1745	2894	-495	4144	756	5394	2006	6645	3257	9146	5758
FS 1600	10	2173	1369	6464	5540	8510	7586	10557	9633	12603	11679	14650	13726	16696	15772	18743	17819	22836	21911
	20	4346	2738	4890	3042	6937	5088	8983	7135	11030	9181	13076	11228	15123	13274	17169	15321	21262	19414
	30	6519	4107	3317	544	5363	2591	7410	4637	9456	6684	11503	8730	13549	10776	15595	12823	19688	16916
	40	8692	5476	1743	-1954	3790	93	5836	2139	7882	4186	9929	6232	11975	8279	14022	10325	18115	14418
	50	10865	6845	169	-4451	2216	-2405	4262	-358	6309	1688	8355	3734	10402	5781	12448	7827	16541	11920
	60	13038	8214	-1404	-6949	642	-4903	2689	-2856	4735	-810	6782	1237	8828	3283	10875	5330	14968	9423
FS 2500	10	3503	2207	10420	8930	13719	12229	17018	15528	20317	18827	23616	22126	26915	25425	30214	28724	36812	35322
	20	7006	4414	7883	4904	11182	8203	14481	11502	17780	14801	21079	18100	24378	21399	27678	24698	34276	31296
	30	10509	6621	5347	877	8646	4176	11945	7475	15244	10774	18543	14073	21842	17372	25141	20671	31739	27269
	40	14012	8828	2810	-3149	6109	150	9408	3449	12707	6748	16006	10047	19305	13346	22604	16645	29202	23243
	50	17515	11035	273	-7176	3572	-3877	6871	-578	10170	2721	13469	6020	16768	9319	20067	12618	26665	19216
	60	21018	13242	-2263	-11202	1036	-7903	4335	-4604	7634	-1305	10933	1994	14232	5293	17531	8592	24129	15190
FS 4000	10	5605	3531	16673	14289	21952	19568	27230	24847	32509	30125	37788	35404	43066	40683	48345	45961	58903	56519
	20	11210	7063	12614	7846	17893	13125	23171	18404	28450	23683	33729	28961	39008	34240	44286	39519	54844	50076
	30	16816	10594	8555	1404	13834	6682	19112	11961	24391	17240	29670	22518	34949	27797	40227	33076	50785	43633
	40	22421	14125	4496	-5039	9775	240	15054	5518	20332	10797	25611	16076	30890	21354	36168	26633	46726	37190
	50	28026	17656	437	-11482	5716	-6203	10995	-925	16273	4354	21552	9633	26831	14912	32109	20190	42667	30748
	60	33631	21188	-3622	-17925	1657	-12646	6936	-7367	12214	-2089	17493	3190	22772	8469	28050	13747	38608	24305

Note:

1. Emerson Process Management recommends that the valve manufacturer supply the maximum required torque values (Including any adjustments or suggested safety factors for valve service conditions or application).
2. Additionally, the valve manufacturer must identify at which position(s) and direction(s) of rotation (Counter Clock Wise or Clock Wise) these maximum requirements occur.
3. If in doubt, or you require any assistance with sizing actuators, do not hesitate to contact your nearest Emerson's Valve Automation Division representative.

Figure 1. Spring Return torque diagram

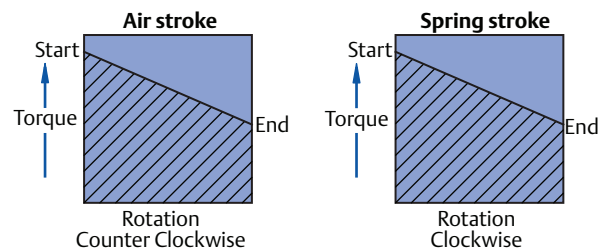

Actuator Torque - Double Acting (Nm)

Actuator Size	Torque in Nm Supply Pressure (barg)										
	2	3	3.5	4	4.5	5	5.5	6	6.5	7	8
FD 12	4.8	7.3	8.5	9.7	10.9	12.2	13.4	14.6	15.9	17.1	19.6
FD 25	9	13	16	18	20	23	25	27	29	32	36
FD 40	17	25	29	34	38	42	47	51	55	59	68
FD 65	25	38	45	51	58	64	71	77	84	90	103
FD 100	38	57	66	76	86	95	105	115	124	134	153
FD 150	60	91	106	122	137	153	168	183	199	214	245
FD 200	82	124	146	167	188	209	230	251	272	293	335
FD 350	143	216	253	290	326	363	400	436	473	510	583
FD 600	243	368	430	492	554	617	679	741	804	866	991
FD 950	377	570	667	764	861	957	1054	1151	1247	1344	1537
FD 1600	617	934	1092	1250	1408	1567	1725	1883	2041	2200	2516
FD 2500	995	1505	1760	2015	2270	2525	2780	3036	3291	3546	4056
FD 4000	1592	2408	2816	3225	3633	4041	4449	4857	5265	5673	6490

Note:

1. Emerson Process Management recommends that the valve manufacturer supply the maximum required torque values (Including any adjustments or suggested safety factors for valve service conditions or application).
2. Additionally, the valve manufacturer must identify at which position(s) and direction(s) of rotation (Counter Clock Wise or Clock Wise) these maximum requirements occur.
3. If in doubt, or you require any assistance with sizing actuators, do not hesitate to contact your nearest Emerson's Valve Automation Division representative.

Figure 1. Double acting torque diagram

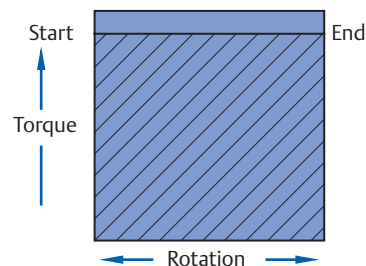

Actuator Torque - Double Acting (lbf.in)

Actuator Size	Torque in lbf.in Supply pressure (psig)												
	30	35	40	45	50	55	60	70	75	80	90	100	120
FD 10	44	51	59	66	74	81	89	104	112	119	134	149	179
FD 25	81	95	109	123	137	151	165	193	207	220	248	276	332
FD 40	153	179	205	231	257	283	309	361	387	413	466	518	622
FD 65	233	272	312	352	392	431	471	550	590	630	709	789	948
FD 100	344	403	461	520	579	638	696	814	873	931	1049	1166	1401
FD 150	551	645	739	833	927	1021	1115	1304	1398	1492	1680	1868	2244
FD 200	754	883	1011	1140	1269	1398	1527	1784	1913	2042	2299	2557	3072
FD 350	1310	1534	1758	1981	2205	2429	2653	3100	3324	3547	3995	4442	5337
FD 600	2226	2606	2987	3367	3747	4127	4508	5268	5648	6028	6789	7549	9070
FD 950	3455	4045	4636	5226	5816	6406	6996	8177	8767	9357	10537	11717	14078
FD 1600	5655	6621	7586	8552	9518	10484	11450	13381	14347	15313	17244	19176	23039
FD 2500	9116	10673	12230	13787	15344	16900	18457	21571	23128	24685	27799	30913	37141
FD 4000	14586	17077	19568	22060	24551	27042	29533	34516	37007	39498	44481	49463	59428

Note:

1. Emerson Process Management recommends that the valve manufacturer supply the maximum required torque values (Including any adjustments or suggested safety factors for valve service conditions or application).
2. Additionally, the valve manufacturer must identify at which position(s) and direction(s) of rotation (Counter Clock Wise or Clock Wise) these maximum requirements occur.
3. If in doubt, or you require any assistance with sizing actuators, do not hesitate to contact your nearest Emerson's Valve Automation Division representative.

Figure 2. Double acting torque diagram

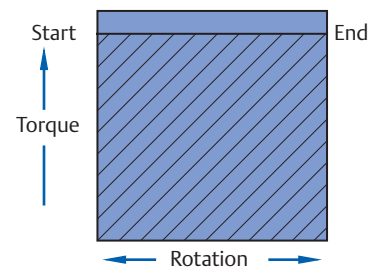

Sizing of Rack & Pinion actuators

Sizing is the selection procedure to select the right size of actuator on a valve with a given torque characteristic. This data sheet gives brief samples on how to size actuators and which data is needed.

Torque characteristics of valves

EL-O-Matic F actuators are commonly used to operate butterfly-, ball- and plug valves. The below instructions are intended for these valve applications, but can also be used for other quarter turn applications.

Figure 1. Generic torque characteristic of a valve

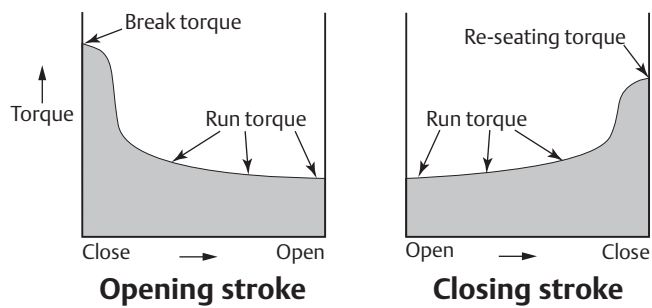

Valve torque values and safety factors

Emerson Process Management recommends that the valve manufacturer supply the maximum required and allowed torque values (Including any adjustments or suggested safety factors for valve service conditions or application).

Additionally, the valve manufacturer must identify at which position(s) and direction(s) of rotation (Counter Clock Wise or Clock Wise) these maximum requirements occur.

If in doubt, or you require any assistance with sizing actuators, do not hesitate to contact your nearest Emerson's Valve Automation representative.

Sizing Double acting actuators

Figure 2. Double acting torque characteristic

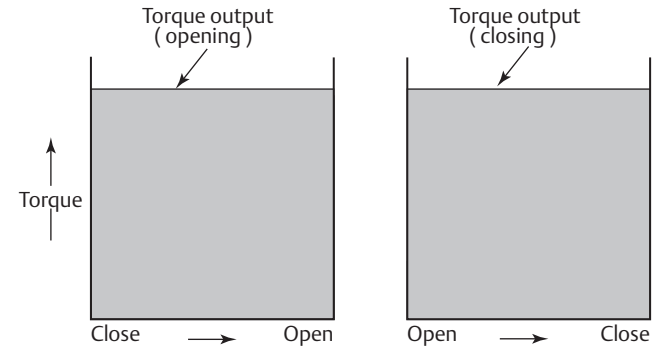

Sample calculation of double acting sizing

- Publish valve break torque: 40 Nm 354 lbf.in
- Publish maximum stem torque: 105 Nm 929 lbf.in
- Recommended safety factor: 1.2 (20%)
- Minimum supply pressure: 5.5 bar 80 psi
- Maximum supply pressure: 6.5 bar 94 psi

Calculation:

1. Because the recommended safety factor is 1.2 the sizing torque will be $40 \times 1.2 = 48 \text{ Nm}$ ($354 \times 1.2 = 425 \text{ lbf.in}$).
2. Lookup in the double acting torque table, in the 5.5 bar column (or 80 psi column), from top down, the first actuator size that generates more than 48 Nm (or 425 lbf.in).
3. Size FD65 is the first actuator that supplies more than
 - a. 48 Nm (71 Nm) at 5.5 bar.
 - b. 425 lbf.in (630 lbf.in.) at 80 PSI.
4. The maximum torque output of a FD65 is 84 Nm (743 lbf.in). This is lower than the maximum stem torque of 105Nm.

Conclusion

Because FD65 supplies more torque than the sizing torque (see point 3) and less than the maximum stem torque (see point 4), size FD65 is suitable to operate this valve.

Sizing spring return actuators

Figure 3. Spring-to-Close configuration

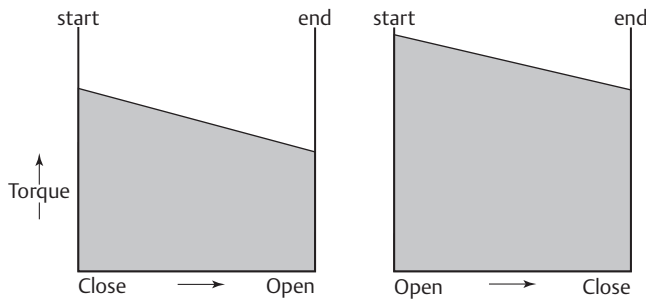

Table 1. For Fail-to Close actuators applies:

Actuator stroke:	Valve Stroke:
Air-Start torque	> Break torque and
Air-End torque	> Run open torque and
Spring-Start torque	> Run open torque and
Spring-End torque	> Re-seat torque

Table 2. For Fail-to Open actuators applies:

Actuator stroke:	Valve Stroke:
Spring-Start torque	> Break torque and
Spring-End torque	> Run torque and
Air-Start torque	> Run torque and
Air-End torque	> Re-seat torque

Sample calculation spring return sizing for a Spring-to-Close application

- Published valve torques
 - Break torque: 150 Nm 1328 lbf.in
 - Run torque opening: 45 Nm 398 lbf.in
 - Run torque closing: 45 Nm 398 lbf.in
 - Re-seating torque; 90 Nm 797 lbf.in
- Publish maximum stem torque: 375 Nm 3496 lbf.in
- Recommended safety factor: 1.5 (50%)
- Minimum supply pressure: 5.5 bar 80 psi
- Maximum supply pressure: 6.0 bar 87 psi

Calculation:

1. Because the recommended safety factor is 1.5 the sizing torques will be:
 - Break 150 Nm x 1.5 = 225 Nm 1991 lbf.in
 - Run open 45 Nm x 1.5 = 67.5 Nm 597 lbf.in
 - Run close 45 Nm x 1.5 = 67.5 Nm 597 lbf.in
 - Re-seat 90 Nm x 1.5 = 135 Nm 1195 lbf.in
2. Lookup in the spring return torque table, in the "spring end" torque column, from top down, the first actuator size that generates more than 135 Nm (or 1195 lbf.in) of re-seat torque.
3. Size FS350 with spring set 4 is the first actuator that supplies more spring end torque (149 Nm or 1655 lbf.in).
4. Check now for the other three positions whether the actuator torque exceeds the valve torques.

Actuator stroke:	Valve Stroke:
Air-Start: 252 Nm	> Break open: 225 Nm.
Air-End: 157 Nm	> Run open: 67.5 Nm.
Spring-Start: 232 Nm	> Run close: 67.5 Nm.
Spring-End: 149 Nm	> Re-seat: 135 Nm
5. The maximum torque output of a FS350 with springset 4 at maximum pressure of 6 bar is 291 Nm (2575 lbf.in). This is lower than the maximum stem torque of 375 Nm (3496 lbf.in).

Conclusion

Because FS350 n=40 supplies more torque than the sizing torque (see point 3) and less than the maximum stem torque (see point 5), size FS350 n=40 is suitable to operate this valve.

Note:

- If the first found actuator does not exceed the valve torque at all the positions, check the next size actuator.
- If the next size actuator does exceed the valve torque at all the positions, but fails at maximum stem torque check whether the same actuator but with a higher springset (i.e. 50 instead of 40) does meet this requirement.

Spring cartridge placement

When replacing spring cartridges in a spring return actuator, ensure that the cartridges are replaced in their identical position from where they were removed.

Check below figure to see where to place the spring cartridges in case of spring set conversion.

Before assembling the spring cartridges and end caps, make sure that the pistons are completely inwards.

Figure 1. Spring cartridge placement

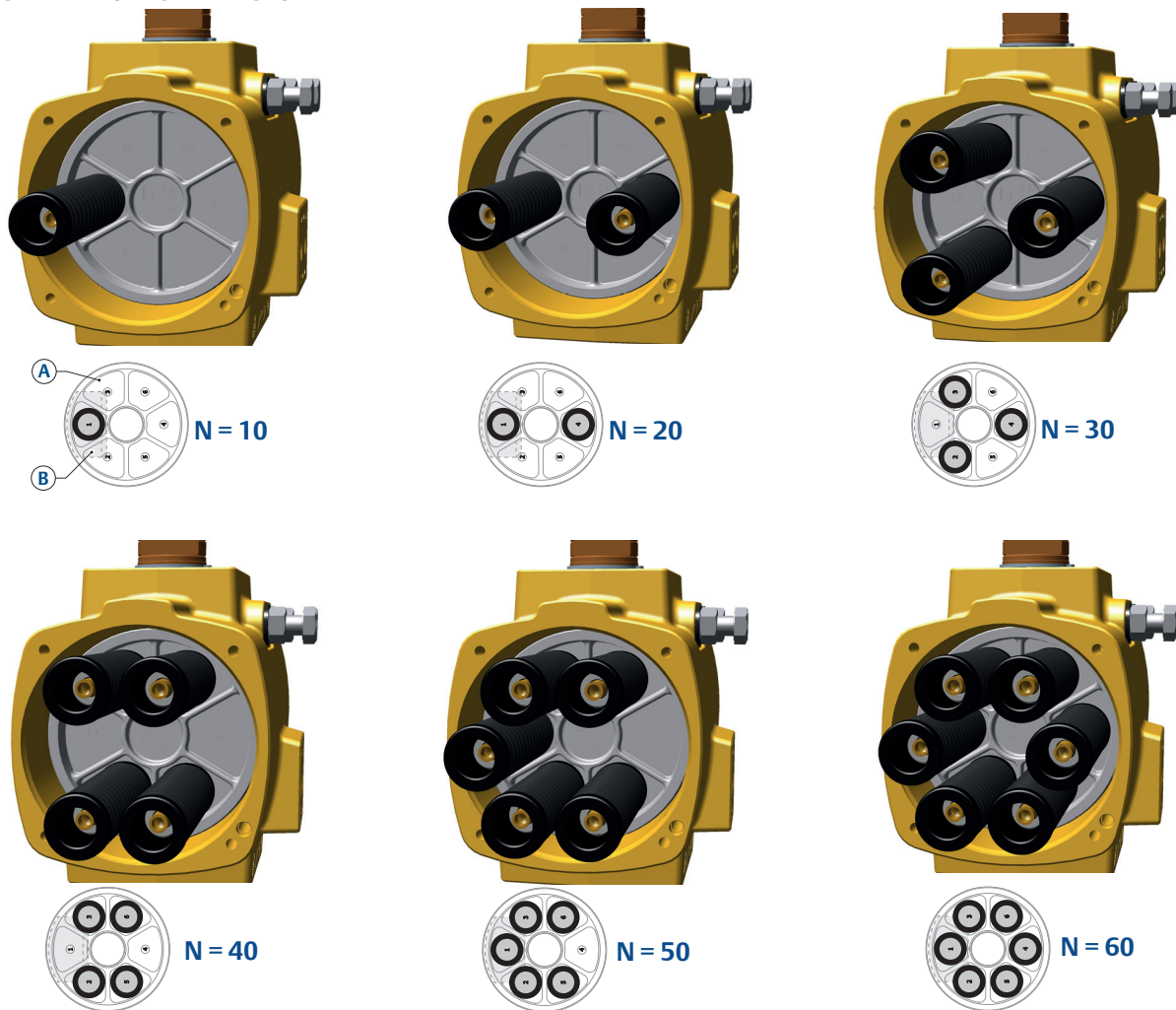

A = Piston top view
B = Position of piston gear rack

Metric - ISO5211

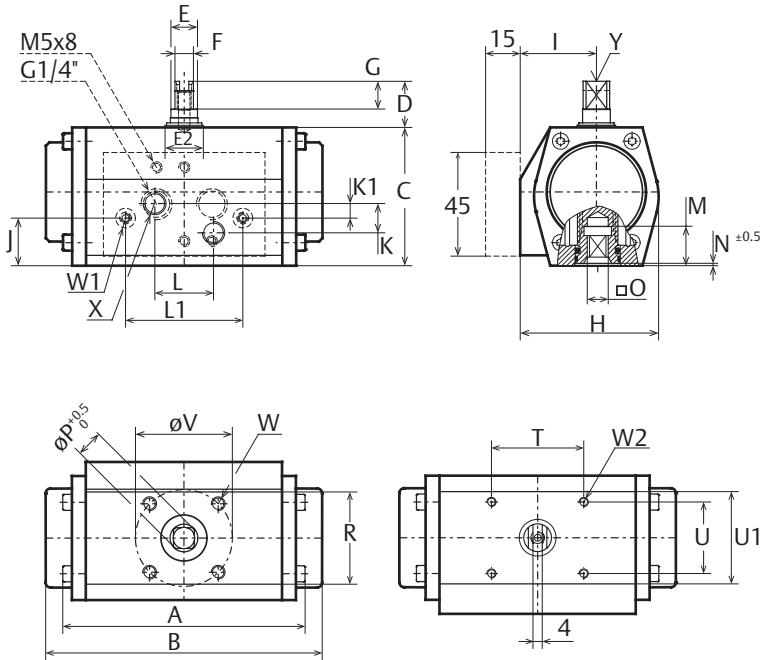

Dim in mm.		Size 12										
A	FD	B	F	S	C	D	E	E2	F	G	H	I
103	118	60	20	16	23	10	12	60	33			
J	K	K1	L	L1	M	N	O max.	O min.	P			
21	12.7	6.4	25.4	50.8	16.5	1	9.14	9.05	12.1			
R	R1	T	U	V	W	W1	W2	X	Y			
40	40	40	31	42	M6x8	M4x7	M4x7	G1/8"	M6x12			

Torque Output																					
Spring Return																					
Spring set	Spring Stroke Torque		Air Stroke Torque (Nm)																		
			3.0 barg		3.5 barg		4.0 barg		4.5 barg		5.0 barg		5.5 barg		6.0 barg		7.0 barg		8.0 barg		
	Start	End	Start	End	Start	End	Start	End	Start	End	Start	End	Start	End	Start	Start	Start	End	Start	End	
2	7.2	4.6	-	-	3.8	1	5.1	2.3	6.4	3.6	7.7	4.9	9.0	6.2	10.3	7.5	12.9	10.1	15.6	12.8	
Double acting			7.3		8.5		9.7		11.0		12.2		13.4		14.6		17.1		19.6		

Notes:

- Volume is the actual free air volume at 1 atm
- Flange and square drive to ISO 5211
- Option: Solenoid mounting interface according to VDI/VDE 3845 (NAMUR). See dotted image.
- For further information regarding options, materials, certifications and additional execution please contact your regional sales office

European Directives:

- PED : suitable for use with group 2 gases according to Pressure Equipment Directive 97/23/EC
- ATEX : suitable for use in hazardous areas classified II 2 GD, zones 1 or 2 (gases) and 21 or 22 (dust).

Principle			
Pneumatic rack & pinion actuator			
General data			
Bore		46	mm
Stroke		12.6	mm
Weight	SR	0.6	kg
	DA	0.7	kg
Volume	Port A	0.05	L
	Port B	0.06	L
Air connection		2x 1/8"	BSP
Pressure range	MOP	8	barg
	SR	3-8	barg
	DA	0.2 - 8	barg
Pressure media		Clean, dry or lubricated air or inert gas.	
Cycle speed DA	Open	0.4	Sec.
	Close	0.4	Sec.
Cycle speed SR	Open	0.4	Sec.
	Close	0.4	Sec.
Temperature range		-20°C to +80°C	
Lubrication		Lubricated for life (1)	
Stroke		90°	
Finish		Polyurethan powder coat	

- According to EN 15714-3.
- Test conditions:
Solenoid with flow capacity: 0.6 m³/hr; Pipe diameter: 6mm; Medium: clean air, Supply pressure: 5.5 barg ~ 80psig; Load: with average load; Stroke: 90°; Temperature: Room temperature

Imperial - ISO5211

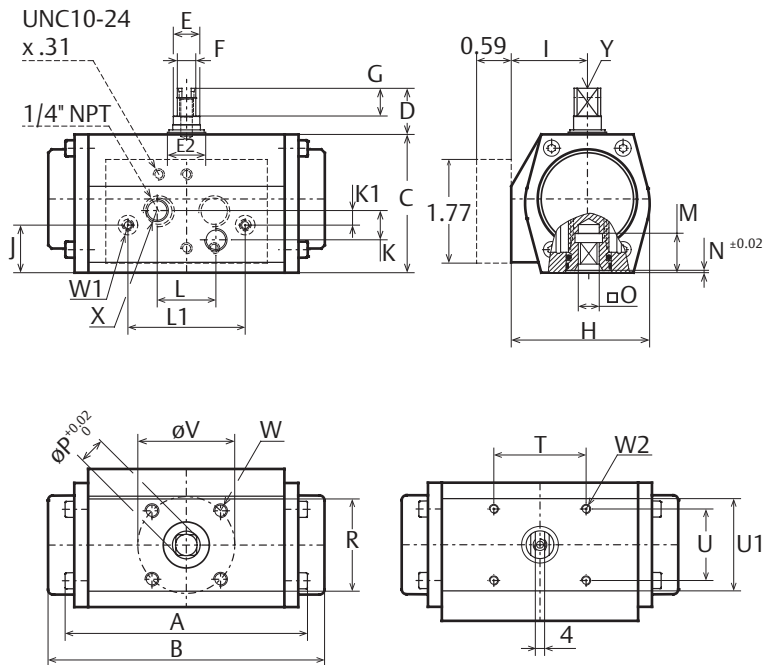

Dim in mm.	Size 12									
A	E	D	B	E	E2	F	G	H	I	
103	118	60	20	16	23	10	12	60	33	
J	K	K1	L	L1	M	N	O max.	O min.	P	
21	12.7	6.4	25.4	50.8	16.5	1	9.14	9.05	12.1	
R	R1	T	U	V	W	W1	W2	X	Y	
40	40	40	31	42	M6x8	M4x7	M4x7	G1/8"	M6x12	

Principle			
Pneumatic rack & pinion actuator			
General data			
Bore		1.811	inch
Stroke		0.496	inch
Weight	SR	1.3	lb
	DA	1.5	lb
Volume	Port A	3.1	cu.in.
	Port B	3.7	cu.in.
Air connection		2x 1/4"	NPT
Pressure range	MOP	116	psig
	SR	43 - 116	psig
	DA	3 - 116	psig
Pressure media		Clean, dry or lubricated air or inert gas.	
Cycle speed DA ⁽²⁾	Open	0.4	Sec.
	Close	0.4	Sec.
Cycle speed SR ⁽²⁾	Open	0.4	Sec.
	Close	0.4	Sec.
Temperature range		-40°F to +176°C	
Lubrication		Lubricated for life ⁽¹⁾	
Stroke		90°	
Finish		Polyurethane powder coat	

1. According EN 15714-3.

2. Test conditions:

Solenoid with flow capacity: 21 foot³/hr; Pipe diameter: 1/4";
Medium: clean air, Supply pressure: 5.5 barg ~ 80psig; Load:
with average load; Stroke: 90°; Temperature: Room temperature

Torque Output																				
Spring Return		Air Stroke Torque (Nm)																		
Spring set	Spring Stroke Torque		3.0 barg		3.5 barg		4.0 barg		4.5 barg		5.0 barg		5.5 barg		6.0 barg		7.0 barg		8.0 barg	
	Start	End	Start	End	Start	End	Start	End	Start	End	Start	End	Start	End	Start	End	Start	End	Start	End
2	7.2	4.6	-	-	3.8	1	5.1	2.3	6.4	3.6	7.7	4.9	9.0	6.2	10.3	7.5	12.9	10.1	15.6	12.8
Double acting			7.3		8.5		9.7		11.0		12.2		13.4		14.6		17.1		19.6	

Notes:

- Volume is the actual free air volume at 1 atm
- Flange and square drive to ISO 5211
- Option: Solenoid mounting interface according to VDI/VDE 3845 (NAMUR). See dotted image.
- For further information regarding options, materials, certifications and additional execution please contact your regional sales office

European Directives:

- PED : suitable for use with group 2 gases according to Pressure Equipment Directive 97/23/EC
- ATEX : suitable for use in hazardous areas classified II 2 GD, zones 1 or 2 (gases) and 21 or 22 (dust).

Metric - DIN3337

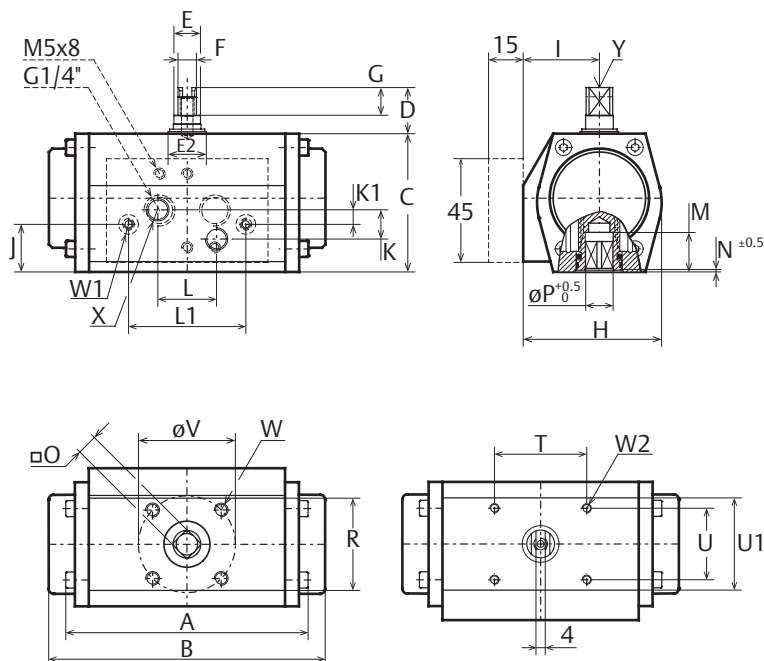

Dim in mm.		Size 12									
A ED	BES	C	D	E	E2	F	G	H	I		
103	118	60	20	16	23	10	12	60	33		
J	K	K1	L	L1	M	N	O max.	O min.	P		
21	12.7	6.4	25.4	50.8	16.5	1	9.14	9.05	12.1		
R	R1	T	U	V	W	W1	W2	X	Y		
40	40	40	31	42	M6x8	M4x7	M4x7	G1/8"	M6x12		

Principle			
Pneumatic rack & pinion actuator			
General data			
Bore		46	mm
Stroke		12.6	mm
Weight	SR	0.6	kg
	DA	0.7	kg
Volume	Port A	0.05	L
	Port B	0.06	L
Air connection		2x 1/8"	BSP
Pressure range	MOP	8	barg
	SR	3-8	barg
	DA	0.2 - 8	barg
Pressure media		Clean, dry or lubricated air or inert gas.	
Cycle speed DA	Open	0.4	Sec.
	Close	0.4	Sec.
Cycle speed SR	Open	0.4	Sec.
	Close	0.4	Sec.
Temperature range		-20°C to +80°C	
Lubrication		Lubricated for life (1)	
Stroke		90°	
Finish		Polyurethan powder coat	

1. According EN 15714-3.
2. Test conditions:
Solenoid with flow capacity: 0.6 m³/hr; Pipe diameter: 6mm; Medium: clean air, Supply pressure: 5.5 barg ~ 80psig; Load: with average load; Stroke: 90°; Temperature: Room temperature

Torque Output																				
Spring Return																				
Spring set	Spring Stroke Torque		Air Stroke Torque (Nm)																	
			3.0 barg		3.5 barg		4.0 barg		4.5 barg		5.0 barg		5.5 barg		6.0 barg		7.0 barg		8.0 barg	
	Start	End	Start	End	Start	End	Start	End	Start	End	Start	End	Start	End	Start	End	Start	End	Start	End
2	7.2	4.6	-	-	3.8	1	5.1	2.3	6.4	3.6	7.7	4.9	9.0	6.2	10.3	7.5	12.9	10.1	15.6	12.8
Double acting			7.3		8.5		9.7		11.0		12.2		13.4		14.6		17.1		19.6	

Notes:

- Volume is the actual free air volume at 1 atm
- Flange and square drive to ISO 5211
- Option: Solenoid mounting interface according to VDI/VDE 3845 (NAMUR). See dotted image.
- For further information regarding options, materials, certifications and additional execution please contact your regional sales office

European Directives:

- PED : suitable for use with group 2 gases according to Pressure Equipment Directive 97/23/EC
- ATEX : suitable for use in hazardous areas classified II 2 GD, zones 1 or 2 (gases) and 21 or 22 (dust).

Dimensions - Metric (ISO5211)

Envelope dimensions - Solenoid interface - Top mounting interface

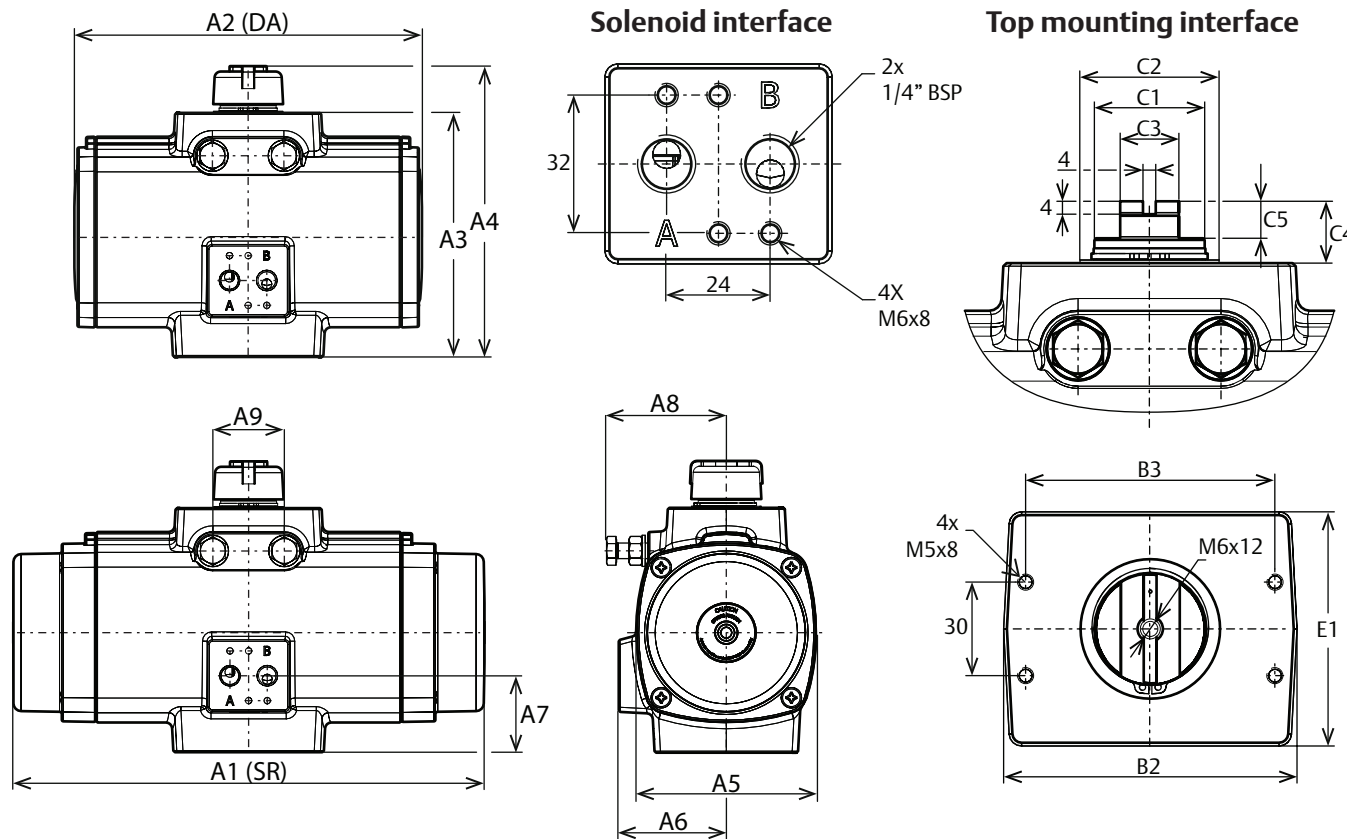

Note:

1. DA = Double Acting, SR = Spring Return
2. Solenoid interface and top mounting interface according VDI/VDE3845 (NAMUR)

Tolerance limits unless otherwise specified:
 X. = ± 0.5 mm
 X.X = ± 0.25 mm
 X.XX = ± 0.1 mm

Dim. in	Actuator size												
	mm	0025	0040	0065	0100	0150	0200	0350	0600	0950	1600	2500	4000
A1	166	192	217	247	304	362	385	476	xxx	xxx	xxx	xxx	xxx
A2	166	192	217	247	223	256	269	336	xxx	xxx	xxx	xxx	xxx
A3	91	112	124	131	157	163	201	248	xxx	xxx	xxx	xxx	xxx
A4	119	139	151	158	185	191	230	292	xxx	xxx	xxx	xxx	xxx
A5	82	95	104	115	127	134	165	199	xxx	xxx	xxx	xxx	xxx
A6	49	55	58	64	69	72	85	102	xxx	xxx	xxx	xxx	xxx
A7	48	58	69	69	75	87	109	132	xxx	xxx	xxx	xxx	xxx
A8	52	65	64	68	92	92	93	115	xxx	xxx	xxx	xxx	xxx
A9	18	25	27	28	46	46	46	60	xxx	xxx	xxx	xxx	xxx
B1	41	43	48	58	73	73	83	98	xxx	xxx	xxx	xxx	xxx
B2	92	92	92	95	92	92	98	148	xxx	xxx	xxx	xxx	xxx
B3	80	80	80	80	80	80	80	130	130	130	130	130	130
C1	16	22	22	22	36	36	36	55	55	64	55	64	64
C2	23	30	30	30	45	45	45	65	65	75	65	80	80
C3	14	14	14	14	19	19	19	36	36	36	36	36	36
C4	20	20	20	20	20	20	20	30	30	30	30	30	30
C5	12	12	12	12	12	12	12	10	10	10	10	10	10

Dimensions - Metric (ISO5211)

Valve Flange and Drive details

Size 25
to 950

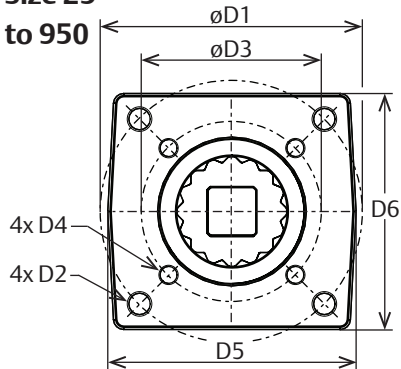

Size 1600
& 2500

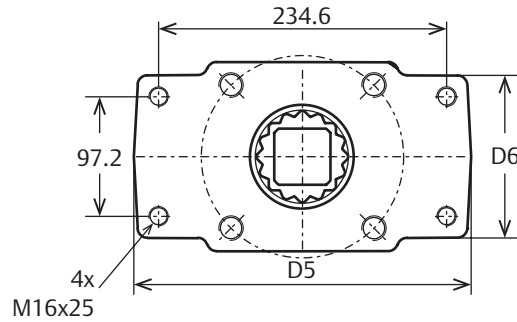

Note:

1. Flange and square drive according to ISO 5211

Tolerance limits unless otherwise specified:

X. = ± 0.5 mm

X.X = ± 0.25 mm

X.XX = ± 0.1 mm

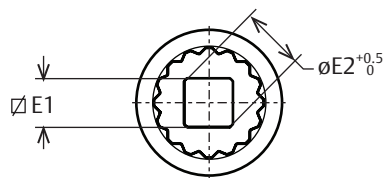
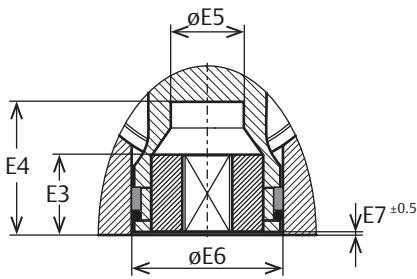

Size 4000

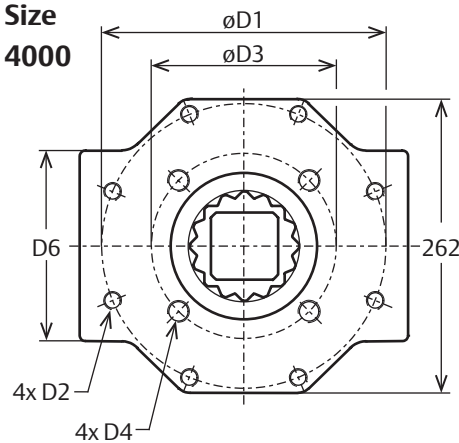

Dim in.	Actuator size											
mm	0025	0040	0065	0100	0150	0200	0350	0600	0950	1600	2500	4000
ISO 1	F05	F07	F07	F07	F10	F10	F10	F12	F14	F16	F16	F25
D1	50	70	70	70	70	102	102	125	125	165	165	254
D2	M6x10	M8x13	M8x13	M8x13	M8x13	M10x15	M10x15	M12x18	M12x18	M20x20	M20x20	M16x25
ISO 2	F03	F05	F05	F05	F07	F07	F07	F10	F10	F25*	F25*	F16
D3	36	50	50	50	70	70	70	102	102	-/-	-/-	165
D4	M5x8	M6x10	M6x10	M6x10	M8x13	M8x13	M8x13	M10x16	M10x16	-/-	-/-	M20x20
D5	48	66	66	66	95	92	92	118	xx.x	xx.x	xx.x	xx.x
D6	46	63	63	63	90	88	92	113	xx.x	xx.x	xx.x	xx.x
E1 Max	11.08	14.08	14.08	19.08	19.08	22.1	27.11	27.11	36.16	46.16	46.16	55.24
E1 Min	11.00	14.00	14.00	19.00	19.00	22.00	27.00	27.00	36.00	46.00	46.00	55.00
E2	14.1	18.1	18.1	25.2	25.5	28.2	36.2	36.21	58.2	60.2	60.2	72.2
E3	15	15	15	18	27.5	27.5	27.5	27.5	xx.x	xx.x	xx.x	xx.x
E4	34	34	34	34	50	50	50	50	xx.x	xx.x	xx.x	xx.x
E5	14.1	18.1	21.1	23.5	28.5	32.1	32.1	36.5	xx.x	xx.x	xx.x	xx.x
E6	24.5	34.5	34.5	38	56.5	56.5	56.5	67.5	xx.x	xx.x	xx.x	xx.x
E7	0.5	1.0	1.0	1.0	1.0	1.0	1.0	1.0	x.x	x.x	x.x	x.x

Dimensions - Metric (DIN3337)

Envelope dimensions - Solenoid interface - Top mounting interface

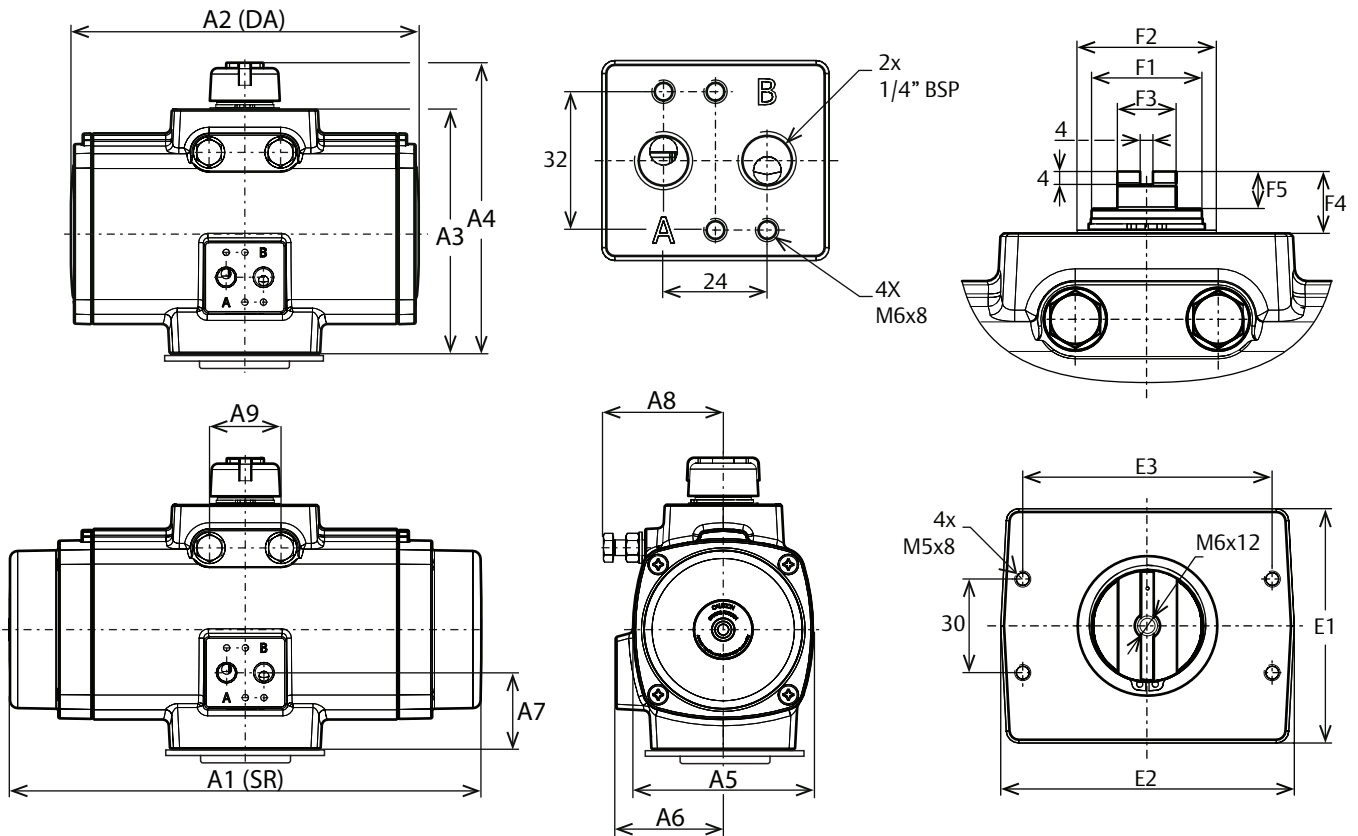

Note:

1. DA = Double Acting, SR = Spring Return
2. Solenoid interface and top mounting interface according VDI/VDE3845 (NAMUR)

Tolerance limits unless otherwise specified:

- X. = ± 0.5 mm
- X.X = ± 0.25 mm
- X.XX = ± 0.1 mm

Dim. in	Actuator size												
	mm	0025	0040	0065	0100	0150	0200	0350	0600	0950	1600	2500	4000
A1	166	192	217	247	304	362	385	476	xxx	xxx	xxx	xxx	xxx
A2	166	192	217	247	223	256	269	336	xxx	xxx	xxx	xxx	xxx
A3	91	112	124	131	157	163	201	248	xxx	xxx	xxx	xxx	xxx
A4	119	139	151	158	185	191	230	292	xxx	xxx	xxx	xxx	xxx
A5	82	95	104	115	127	134	165	199	xxx	xxx	xxx	xxx	xxx
A6	49	55	58	64	69	72	85	102	xxx	xxx	xxx	xxx	xxx
A7	48	58	69	69	75	87	109	132	xxx	xxx	xxx	xxx	xxx
A8	52	65	64	68	92	92	93	115	xxx	xxx	xxx	xxx	xxx
A9	18	25	27	28	46	46	46	60	xxx	xxx	xxx	xxx	xxx
B1	41	43	48	58	73	73	83	98	xxx	xxx	xxx	xxx	xxx
B2	92	92	92	95	92	92	98	148	xxx	xxx	xxx	xxx	xxx
B3	80	80	80	80	80	80	80	130	130	130	130	130	130
C1	16	22	22	22	36	36	36	55	55	64	55	64	64
C2	23	30	30	30	45	45	45	65	65	75	65	80	80
C3	14	14	14	14	19	19	19	36	36	36	36	36	36
C4	20	20	20	20	20	20	20	30	30	30	30	30	30
C5	12	12	12	12	12	12	12	10	10	10	10	10	10

Dimensions - Metric (DIN3337)

Valve Flange and Drive details

Size
25 to
950

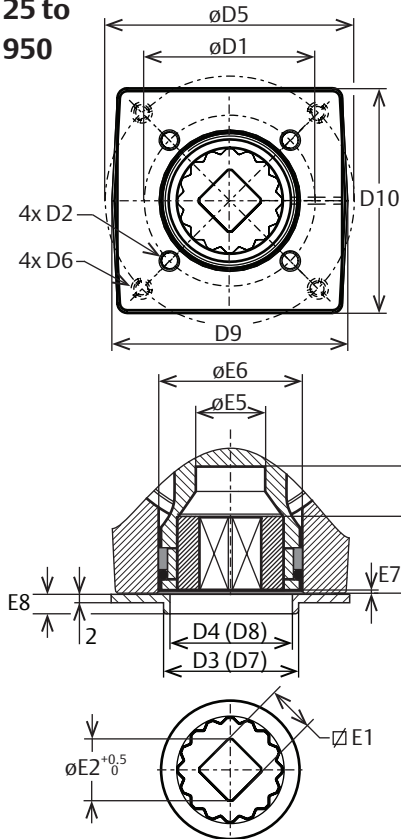

Size 1600
& 2500

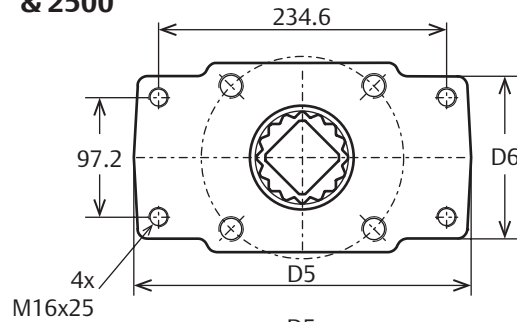

Size
4000

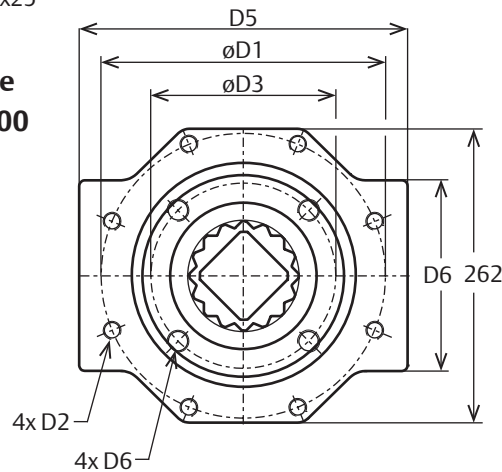

Note:

1. Flange and square drive according to DIN 3337
2. Drilling pattern DIN 1 is default. Drilling pattern DIN 2 is optional.

Tolerance limits unless otherwise specified:
X. = ± 0.5 mm
X.X = ± 0.25 mm
X.XX = ± 0.1 mm

Dim in.	Actuator size											
mm	0025	0040	0065	0100	0150	0200	0350	0600	0950	1600	2500	4000
DIN 1	F05	F05	F05	F07	F07	F10	F10	F12	F14	F16	F16	F25
D1	50	50	50	70	70	102	102	125	125	165	165	254
D2	M6x10	M6x10	M6x10	M8x13	M8x13	M10x15	M10x15	M12x18	M12x18	M20x20	M20x20	M16x25
D3	35	35	35	55	55	70	70	85	100	130	130	200
D4	29	32	32	40	50	54	54	68	75	95	95	120
DIN 2	F03	F07	F07	F05	F10	F07	F07	F10	F10	-/-	-/-	-/-
D5	36	70	70	50	102	70	70	102	102	-/-	-/-	-/-
D6	M5x8	M8x13	M8x13	M6x10	M10x15	M8x13	M8x13	M10x15	M10x15	-/-	-/-	-/-
D7	-	40	40	32	54	50	50	-/-	-/-	-/-	-/-	-/-
D8	-	55	55	35	70	55	55	-/-	-/-	-/-	-/-	-/-
D9	48	66	66	66	95	92	92	118	xx.x	xx.x	xx.x	xx.x
D10	46	63	63	63	90	88	92	113	xx.x	xx.x	xx.x	xx.x
E1 Max.	11.08	14.08	14.08	17.08	17.08	22.10	22.10	27.11	36.16	46.16	46.16	55.24
E1 Min.	11.00	14.00	14.00	17.00	17.00	22.00	22.00	27.00	36.00	46.00	46.00	55.00
E2	14.1	18.1	18.1	25.2	25.5	28.2	36.2	36.21	58.2	60.2	60.2	72.2
E3	15	15	15	18	27.5	27.5	27.5	27.5	xx.x	xx.x	xx.x	xx.x
E4	34	34	34	34	50	50	50	50	xx.x	xx.x	xx.x	xx.x
E5	14.1	18.1	21.1	23.5	28.5	32.1	32.1	36.5	xx.x	xx.x	xx.x	xx.x
E6	24.5	34.5	34.5	38	56.5	56.5	56.5	67.5	xx.x	xx.x	xx.x	xx.x
E7	0.5	1.0	1.0	1.0	1.0	1.0	1.0	1.0	x.x	x.x	x.x	x.x
E8	5	5	5	5	5	5	5	5	6	7	?	?

Dimensions - Imperial (ISO5211)

Envelope dimensions - Solenoid interface - Top mounting interface

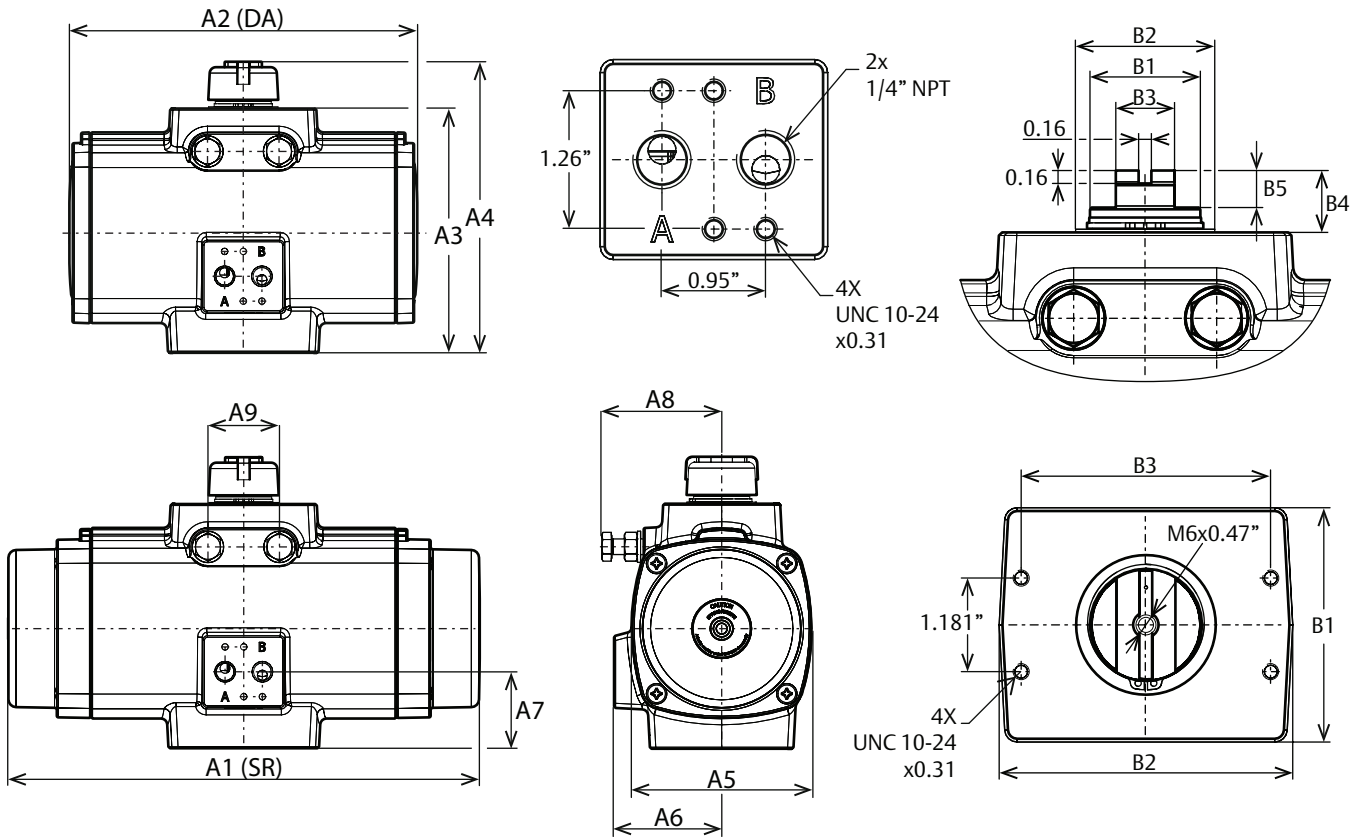

Note:

1. DA = Double Acting, SR = Spring Return
2. Solenoid interface and top mounting interface according VDI/VDE3845 (NAMUR)

Tolerance limits unless otherwise specified:
 X.X = ± 0.02"
 X.XX = ± 0.01"

Dim in.	Actuator size											
Inches	0025	0040	0065	0100	0150	0200	0350	0600	0950	1600	2500	4000
A1	6.54	7.55	8.53	9.72	11.97	14.23	15.15	18.73	xx.xx	xx.xx	xx.xx	xx.xx
A2	6.54	7.55	8.53	9.72	8.8	10.07	10.58	13.21	xx.xx	xx.xx	xx.xx	xx.xx
A3	3.59	4.39	4.86	5.14	6.19	6.42	7.92	9.77	xx.xx	xx.xx	xx.xx	xx.xx
A4	4.69	5.47	5.94	6.22	7.28	7.52	9.06	11.5	xx.xx	xx.xx	xx.xx	xx.xx
A5	3.23	3.74	4.09	4.53	5	5.28	6.5	7.83	xx.xx	xx.xx	xx.xx	xx.xx
A6	1.91	2.15	2.28	2.5	2.72	2.83	3.35	4.02	xx.xx	xx.xx	xx.xx	xx.xx
A7	1.89	2.28	2.72	2.72	2.95	3.43	4.29	5.2	xx.xx	xx.xx	xx.xx	xx.xx
A8	2.05	2.56	2.52	2.68	3.62	3.62	3.66	4.53	xx.xx	xx.xx	xx.xx	xx.xx
A9	0.71	0.98	1.06	1.1	1.81	1.81	1.81	2.36	xx.xx	xx.xx	xx.xx	xx.xx
B1	1.62	1.7	1.89	2.28	2.88	2.88	3.27	3.86	xx.xx	xx.xx	xx.xx	xx.xx
B2	3.62	3.62	3.63	3.75	3.63	3.63	3.86	5.83	xx.xx	xx.xx	xx.xx	xx.xx
B3	3.15	3.15	3.15	3.15	3.15	3.15	3.15	5.12	5.12	5.12	5.12	5.12
C1	0.63	0.87	0.87	0.87	1.42	1.42	1.42	2.17	2.17	2.52	2.17	2.52
C2	0.91	1.18	1.18	1.18	1.77	1.77	1.77	2.56	2.56	2.95	2.56	3.15
C3	0.55	0.55	0.55	0.55	0.75	0.75	0.75	1.42	1.42	1.42	1.42	1.42
C4	0.79	0.79	0.79	0.79	0.79	0.79	0.79	1.18	1.18	1.18	1.18	1.18
C5	0.47	0.47	0.47	0.47	0.47	0.47	0.47	0.39	0.39	0.39	0.39	0.39

Dimensions - Imperial (ISO5211)

Valve Flange and Drive details

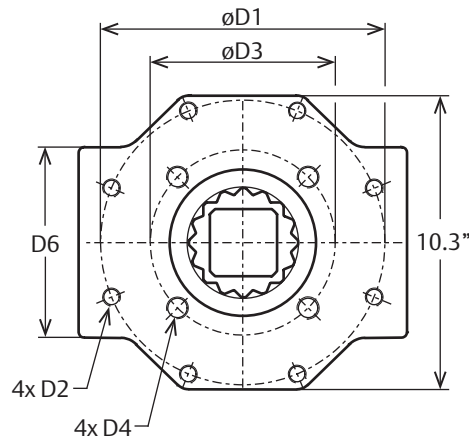
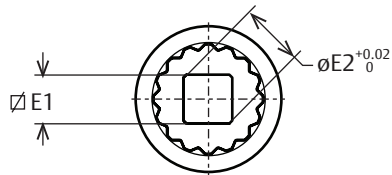
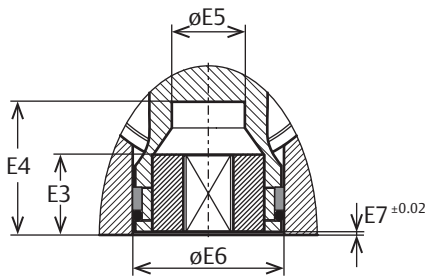
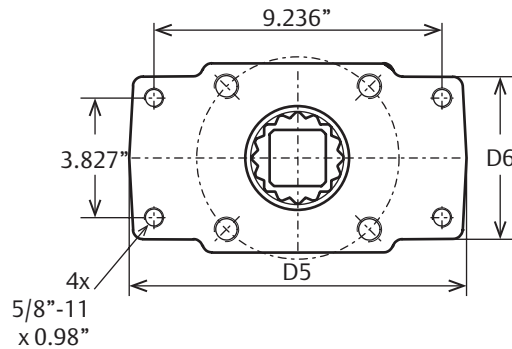
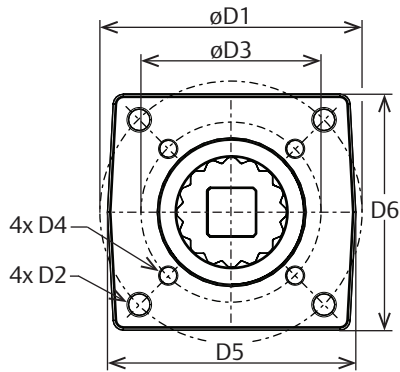

Note:

1. Flange and square drive according to DIN 3337
2. Drilling pattern DIN 1 is default. Drilling pattern DIN 2 is optional.

Tolerance limits unless otherwise specified:
 X.X = $\pm 0.02''$
 X.XX = $\pm 0.01''$

Dim in.	Actuator size											
Inches	0025	0040	0065	0100	0150	0200	0350	0600	0950	1600	2500	4000
ISO 1	F05	F07	F07	F07	F10	F10	F10	F12	F14	F16	F16	F25
D1	1.969	2.756	2.756	2.756	4.016	4.016	4.016	4.921	4.921	6.496	6.496	10
D2	"1/4"-20 x0.39"	"5/16"-18 x0.39"	"5/16"-18 x0.39"	"5/16"-18 x0.39"	"3/8"-16 x0.63"	"3/8"-16 x0.63"	"3/8"-16 x0.63"	"1/2"-13 x0.79"	"5/8"-11 x0.98"	-/-	-/-	"5/8"-11 x0.98"
ISO 2	F03	F05	F05	F05	F07	F07	F07	F10	F10	F25*	F25*	F16
D3	1.417	1.969	1.969	1.969	2.756	2.756	2.756	4.016	4.016	-/-	-/-	6.496
D4	"10-24 x0.31"	"1/4"-20 x0.39"	"1/4"-20 x0.39"	"1/4"-20 x0.39"	"5/16"-18 x0.39"	"5/16"-18 x0.39"	"5/16"-18 x0.39"	"3/8"-16 x0.63"	"3/8"-16 x0.63"	-/-	-/-	"3/4"-10 x1.14"
D5	1.89	2.6	2.62	2.62	3.74	3.63	3.63	4.65	xx.x	xx.x	xx.x	xx.x
D6	1.81	2.48	2.48	2.48	3.54	3.46	3.62	4.45	xx.x	xx.x	xx.x	xx.x
E1 Max	0.436	0.554	0.554	0.751	0.751	0.87	1.067	1.067	1.424	1.817	1.817	2.175
E1 Min	0.433	0.551	0.551	0.748	0.748	0.866	1.063	1.063	1.417	1.811	1.811	2.165
E2	0.555	0.713	0.713	0.992	1.004	1.110	1.425	1.426	2.291	2.370	2.370	2.843
E3	0.591	0.591	0.591	0.709	1.083	1.083	1.083	1.083	xx.x	xx.x	xx.x	xx.x
E4	1.34	1.34	1.34	1.34	1.97	1.97	1.97	1.97	xx.x	xx.x	xx.x	xx.x
E5	0.56	0.71	0.83	0.93	1.12	1.26	1.26	1.44	xx.x	xx.x	xx.x	xx.x
E6	0.96	1.36	1.36	1.5	2.22	2.22	2.22	2.66	x.xxx	x.xxx	x.xxx	x.xxx
E7	0.02	0.04	0.04	0.04	0.04	0.04	0.04	0.04	x.xx	x.xx	x.xx	x.xx

Drive Inserts

Description

The EL-O-Matic F actuators are fitted with drive inserts. These drive inserts allow actuators to be directly mounted onto suitable valves and eliminates the need for a bracket and coupling type mounting kit. The use of direct mounts significantly cuts the cost of the valve/actuator assembly.

Standard actuators are fitted with square drive inserts in accordance with ISO 5211. The ISO 5211 covers now parallel and diagonal oriented inner squares (as per old DIN 3337 standard).

A wide variety of other inserts are also available. Special inserts may have oversized or undersized squares, double-D and shaft key way forms.

Drive inserts can be supplied on factory built actuators or as loose items and are easily replaceable at distributor or end user level.

Where direct mounts are not possible, for instance on valves with exposed grand packing, the use of inserts often simplifies the design of the mounting kit.

- Material: Aluminium alloy
- Finish : Anodized

Note:

Size D12 does not have inserts. This actuator have the inner square directly in the bottom of the pinion.

Table 1. Inserts with inner-square-dimensions per actuator size (metric)

Dim. in mm	Inserts with inner-square-dimensions per actuator type										
	F0025	F0040/ F0065	F0100	F0150	F0200	F0350	F0600	F0950	F1600	F2500	F4000
Standard square insert dimensions											
Parallel: □	11	14	19	19	22	27	27	36	46	46	55
Diagonal: ◇	11	14	17	17	22	22	27	36	46	46	55
Optional square insert dimensions											
	9	10	12	14	14	14	14	22	-	-	??
	10	12	14	16	16	16	16	-	-	-	??
	-	-	16	22	17	17	17	-	-	-	??
	-	-	-	24	19	19	19	-	-	-	??
	-	-	-	27	24	24	24	-	-	-	??
Maximum insert dimensions											
M1	34.5	34.5	34.5	50	50	50	52	64	82	82	??
M2	-	-	27	-	37	37	-	-	-	-	??
P1	14.1	18.1	23.1	28.5	32.1	32.1	36.5	48.5	60.5	60.5	??
P2	-	-	25.2	-	36.2	36.2	-	-	-	-	??
Sq. max.	11	16	19	27	27	27	27	36	46	46	??
D max.	13.8	21	23.6	33.6	33.6	33.6	33.6	45	60	60	??

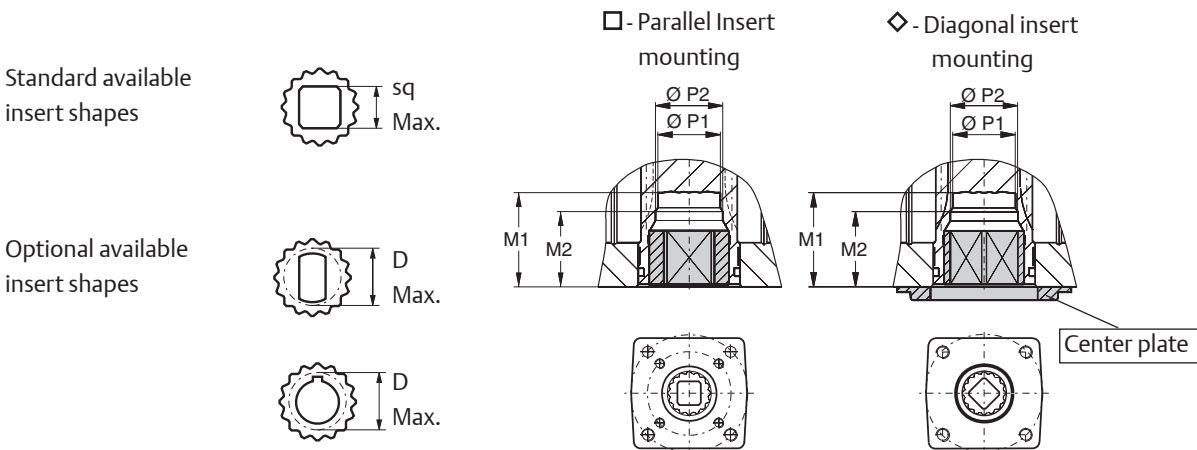

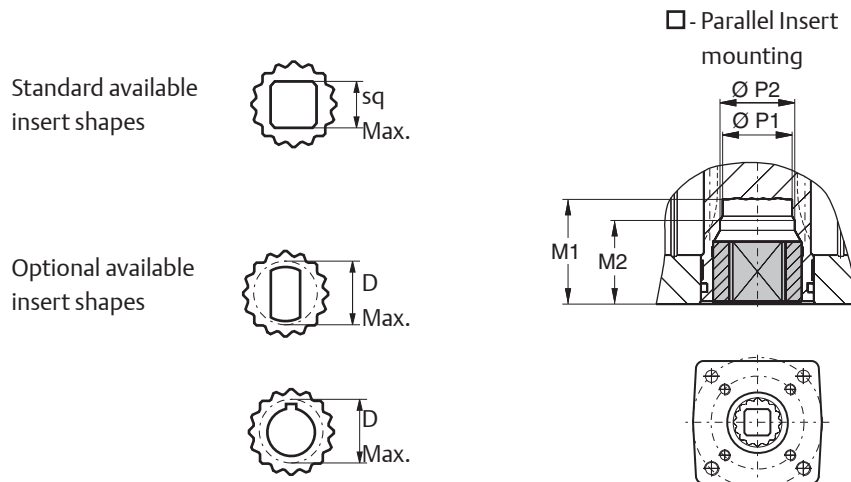

Table 2. Inserts with inner-square-dimensions per actuator size (Imperial)

Dim. In inches	Inserts with inner-square-dimensions per actuator type										
	F0025	F0040/ F0065	F0100	F0150	F0200	F0350	F0600	F0950	F1600	F2500	F4000
Standard square insert dimensions											
Parallel: 	0.433	0.551	0.748	0.748	0.866	1.063	1.063	1.417	1.811	1.811	2.165
Optional square insert dimensions											
	0.354	0.394	0.472	0.551	0.551	0.551	0.551	0.866	-	-	??
	0.394	0.472	0.551	0.630	0.630	0.630	0.630	-	-	-	??
	-	-	0.630	0.866	0.669	0.669	0.669	-	-	-	??
	-	-	-	0.945	0.748	0.748	0.748	-	-	-	??
	-	-	-	1.063	0.945	0.945	0.945	-	-	-	??
Maximum insert dimensions											
M1	1.358	1.358	1.358	1.969	1.969	1.969	2.047	2.520	3.228	3.228	??
M2	-	-	1.063	-	1.457	1.457	-	-	-	-	??
P1	0.555	0.713	0.909	1.122	1.264	1.264	1.437	1.909	2.382	2.382	??
P2	-	-	0.992	-	1.425	1.425	-	-	-	-	??
Sq. max.	0.433	0.630	0.748	1.063	1.063	1.063	1.063	1.417	1.811	1.811	??
D max.	0.543	0.827	0.929	1.323	1.323	1.323	1.323	1.772	2.362	2.362	??



Centering Plate

EL-O-Matic F actuators can be equipped with a centering plate which takes care that actuator and valve (or valve mounting kit) are aligned when mounted. For most of the actuator sizes two centering plates are available.

- Specifications:
 - Material plate: Nylon PA6, Black

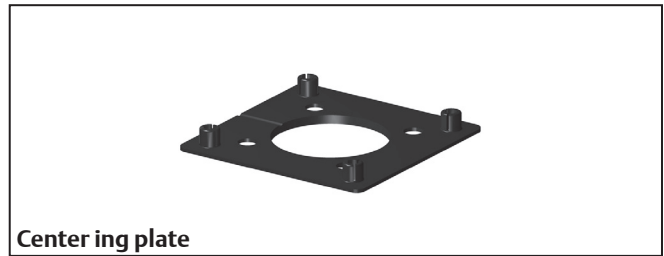

ELOMATIC F actuator models												
	F 25	F 40	F 65	F 100	F 150	F 200	F 350	F 600	F 950	F 1600	F 2500	F 4000
Default*	F05	F05	F05	F07	F07	F10	F10	F12	F14	F16	F16	F25
Option	-/-	F07	F07	F05	F10	F07	F07	F10	-/-	-/-	-/-	-/-

1. * Default selection if actuator needs to comply to DIN 3337, see dimension sheet EFD.04.01.EN.

Visual indicator EL-O-Matic F series actuators

Description

EL-O-Matic F series actuators have a large visual position indicator which allows clear indication of the valves position at almost any position.

EL-O-Matic F series indicator is designed for position indication of actuators mounted "in line" with the pipe line and mounted "cross line" with the pipe line.

Conversion is easily done by turning the indicator 90° and reassemble back in place.

Default, the position indicator will be mounted "in line".

Specifications:

Materials:

- Indicator knob: ABS, Black
- Indicator arrow: ABS, White
- Indicator screw: SS Head cap screw M6x12

Indicator mounting "In line"

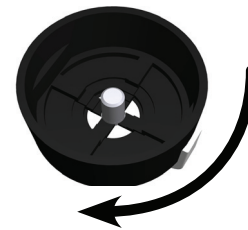
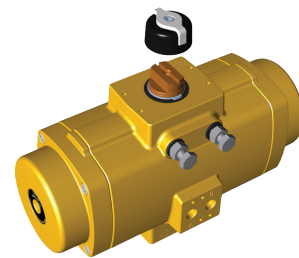
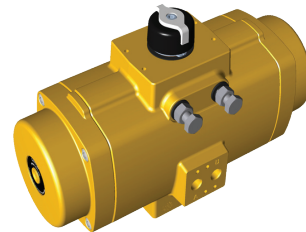

Indicator mounting "Across line"

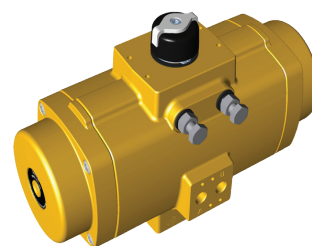

EL-O-Matic F-Series with CSR-coating

"Caustic Soda Resistant"

Description

EL-O-Matic F-Series with CSR-coating have an excellent corrosion resistance in environments where the actuator is in contact with chemicals like caustic soda.

The CSR coating itself is resistant to at least 1000 hours of salt spray test exposure. Together with the excellent mechanical properties, the CSR coating is "the" solution for very harsh environments.

CSR actuator housing and caps are completely coated (inside and out) with a ceramic filled fluoropolymer based epoxy resin, impregnated by a temperature of 240°C into the aluminum surface.

Approximately 40% of the coating is impregnated into the aluminum, 60% stays on the surface of the component as a seal.

Technical data:

Coating:	Ceramic filled fluoropolymer based epoxy resin.
Layer thickness:	20 microns
Corrosion resistance:	1000hr, ASTM B117
Max. temperature:	-20° to + 80°C
Materials Housing:	Aluminum alloy
Shaft:	Aluminum hard anodized (Option : Stainless steel)
Fasteners:	Stainless steel
Type Sticker:	Nylon
Application:	Optional on EL-O-Matic F-series actuator sizes 25 to 1600. Not possible on sizes 2500 or 4000.

Chemical resistances:

Resistance to various inorganic chemicals, organic chemicals, gasolines, oils, detergents, etc. is generally good to excellent, but also depends on temperature and/or concentration.

For more detailed information see page 2.

Pinion:

Hard anodized aluminum
(Option: Stainless steel)

Stainless steel

Coating:

Fasteners:



20 microns Ceramic filled epoxy resin.

Chemical Resistance List for CSR Coating

Inorganic chemicals	
1	Ammonium hydroxide (10%)
1	Calcium chloride (~50%)
3	Chlorine
3	Chromic acid
3	Hydrofluoric acid (50%)
1	Caustic potash solution (10%)
1	Sodium hypochlorite (saturated)
1	Caustic soda solution (10%)
1	Caustic soda solution (saturated)
1	Phosphoric acid (10%)
1	Phosphoric acid (50%)
2	Nitric acid (10%)
3	Nitric acid (50%)
1	Hydrochloric acid (10%)
1	Hydrochloric acid (concentrated)
1	Sulphuric acid (50%)
3	Sulphuric acid (concentrated)
2	Sulphur dioxide
1	Sulphur hexafluoride
2	Nitric oxide
1	Hydrogen peroxide (100%)
Chemicals	
1	Automatic transmission fluid Shell Dextra 11D 20-137 (150°C)
1	Engine oil, mineral, Mihag 1500-40 (150°C)
1	Engine oil, synthetic, Mobil SHC 10 W-40
3	Brake fluid Hydraulan DOT 4
1	Roller bearing grease DIN 51 825

Organic chemicals	
3	Acetone
3	Acetonitrile
3	Aniline
2	Benzene
1	n-Butanol
3	Butyl acetate
3	Chlorobenzene
3	Chloroform
3	o-Chlorophenol
1	Cyclohexane
3	Cyclohexanone
3	1,2-Dichloroethane
2	Diethyl ether
2	Dioxane
1	Glacial acetic acid
1	Ethanol
3	Ethyl acetate
1	Ethylene glycol
1	Formaldehyde
2	Freon 11
2	Freon 22
1	Glycerine
1	Hexane
1	Isooctane
1	Isopropanol
1	Methanol
3	Methylene chloride
3	Methyl ethyl ketone
3	N.N-Dimethylformamide
3	N-Methylpyrrolidon
1	Oxalic acid
1	Perchloroethylene
1	Petroleum ether
3	Phenol
1	Carbon bisulphide
1	Turpentine
2	Tetrachloroethane
2	1,1,1-Trichloroethane
1	Tetrachloromethane
3	Trichloroethylene
2	Toluene
1	Xylene

Fuels/lubricants	
1	Two-star petrol (50°C)
1	Four-star petrol (50°C)
1	Fuel M 15 (50°C)
1	Diesel oil
1	Kerosene
1 to 2	Hypoid bevel gear oil Shell Spirax HD 90 (150°C)
1	Transmission oil Shell Spirax MA 80 (150°C)
Technical detergents	
2	Genkeene
2	1,1,1- Trichloroethane
2	Triklone A
2	Perchloroethylene
Miscellaneous fluids	
1	Glystantin (BASF)/water
1	Plasticizer DOP
1	Suds
1	Washing-up liquids
1	Household detergents
1	Linseed oil
1	Milk
1	Soapsuds
1	Silicone oils

Legend:

1. Excellent
2. Limited resistance; it is recommended to perform field tests under the specified conditions
3. Not recommended

Note:

This list has been composed with great care. However, EL-O-MATIC cannot be held responsible, either for any errors in this list or for their consequences. Because of continued testing this list is subject to change without notice.

High Temperature Execution

Description

A double piston, rack and pinion pneumatic actuator, incorporating an anti-blowout pinion and a piston support system with high duty synthetic bearings at all bearing points.

This version is a standard aluminum actuator, but incorporating grease, O-ring seal and bearing materials, suitable for high temperature operation up to 248°F (120°C).

Specification

Max. pressure: 120 psig (8.3 barg)
 Torque: Standard
 Media: Air or non corrosive gas
 Temperature: -4°F to +248°F (-20°C to +120°C)
 Finish: Polyurethan powder coating
 (see data sheet BRG.01.03.EN)

Spare parts

Dedicated high temperature spare part kits are available for maintenance or to convert a standard actuator in to a version suitable for high temperature operation.

- High temperature components:

 - Castrol High temperature grease
 - Viton (FPM) O-ring seals
 - PTFE 25% carbon filled piston bearings
 - Nylon 66 resin containing Aramid Fibre & PTFE for bearing strip piston rack and pinion bearings.

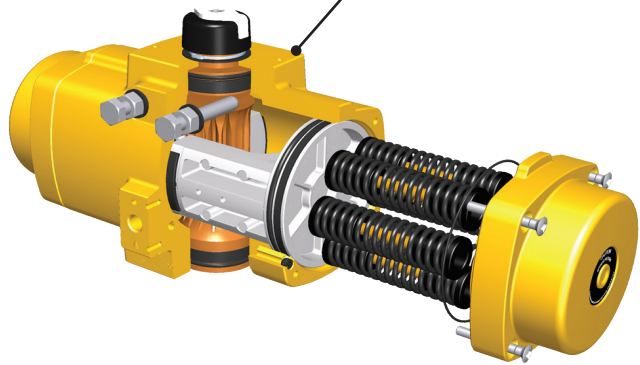

Description	Material
House	Cast Aluminium alloy
End cap	Cast Aluminium alloy
Piston	Cast Aluminium alloy
Pinion	High grade aluminium
Spring cartridge	Spring steel
Bearing strip piston rack	Nylon 66 resin containing Aramid Fibre & PTFE
Bearing piston	PTFE 25% carbon filled
Bearing pinion	Nylon 66 resin containing Aramid Fibre & PTFE
Thrust washer	POM, black UV stabilized
End cap screw	Stainless Steel
Circlip	Spring steel
O-ring seal pinion	Viton FPM
O-ring seal piston	Viton FPM
O-ring seal end cap	Viton FPM
O-ring seal limit stop	Viton FPM
B-port seal	Silicon rubber
Limit stop screw	Stainless steel
Limit stop nut	Stainless steel
Limit stop washer	PA66
Warning sticker	Polyester
Indicator assembly	ABS + stainless steel screw
Center plate (option)	Nylon PA6, Black
Insert drive	Aluminium alloy
Grease	Castrol High temperature grease

Low Temperature Execution

Description

A double piston, rack and pinion pneumatic actuator, incorporating an anti-blowout pinion and a piston support system with high duty synthetic bearings at all bearing points.

This version is a standard aluminum actuator, but incorporating grease and O-ring seal materials, suitable for low temperature operation down to -40°F (-40°C).

Note:

When operating actuators in sub-zero temperatures (< 0°C or < 32°F) care should be taken to counter the effects of freezing condensate inside the actuator.

Specification

Max. pressure:	120 psig (8.3 barg)
Torque:	Standard
Media:	Air or non corrosive gas
Temperature:	-40°C to +80°C (-40°F to +176°F)
Finish:	Polyurethan powder coating (see data sheet BRG.01.03.EN)

Spare parts

Dedicated low temperature spare part kits are available for maintenance or to convert a standard actuator in to a version suitable for low temperature operation.

Low temperature components:
- Castrol Optitemp TT1 grease
- Silicone (MVQ70 rubber) O-ring seals

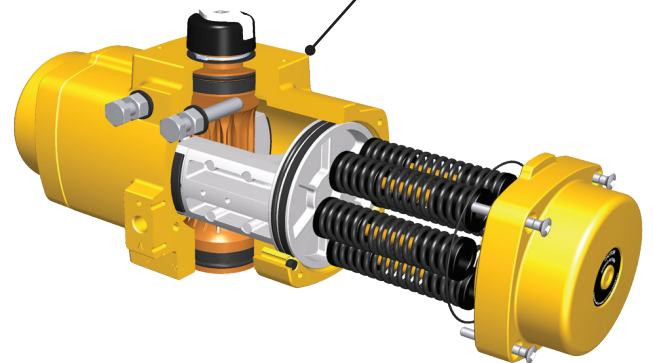

Description	Material
House	Cast Aluminium alloy
End cap	Cast Aluminium alloy
Piston	Cast Aluminium alloy
Pinion	High grade aluminium
Spring cartridge	Spring steel
Bearing strip piston rack	POM
Bearing piston	PTFE 25% carbon filled
Bearing pinion	POM
Thrust washer	POM, black UV stabilized
End cap screw	Stainless Steel
Circlip	Spring steel
O-ring seal pinion	Silicone MVQ70
O-ring seal piston	Silicone MVQ70
O-ring seal end cap	Silicone MVQ70
O-ring seal limit stop	Silicone MVQ70
B-port seal	Silicon rubber
Limit stop screw	Stainless steel
Limit stop nut	Stainless steel
Limit stop washer	PA66
Warning sticker	Polyester
Indicator assembly	ABS + stainless steel screw
Center plate (option)	Nylon PA6, Black
Insert drive	Aluminium alloy
Grease	Castrol Optitemp TT1 grease