

**ARI-STOBU® PN16-40**

Stuffing box valve

Stop valve with gland seal metal seat



**ARI-STOBU® -**

**Straight through with flanges**

- TRB 801 Annex II No. 45 (except EN-JL1040)
- EN ISO 15848-1 / TA - Luft (optional)  
TÜV-Test-No. TA 08 2016 C04

Grey cast iron  
SG iron  
**Fig. 006/306**

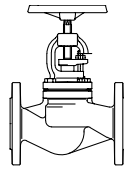

Page 2

**ARI-STOBU® -**

**Straight through with flanges**

- TRB 801 Annex II No. 45
- EN ISO 15848-1 / TA - Luft (optional)  
TÜV-Test-No. TA 08 2016 C04

Cast steel  
**Fig. 006/306**

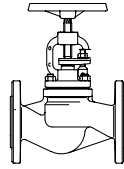

Page 3

**ARI-STOBU® -**

**Straight through with flanges**

- TRB 801 Annex II No. 45
- EN ISO 15848-1 / TA - Luft (optional)  
TÜV-Test-No. TA 08 2016 C04

Forged steel  
**Fig. 006**

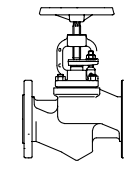

Page 4

**ARI-STOBU® -**

**Straight through with flanges**

- TRB 801 Annex II No. 45
- EN ISO 15848-1 / TA - Luft (optional)  
TÜV-Test-No. TA 08 2016 C04

Stainless steel  
**Fig. 006**

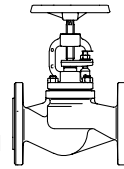

Page 5

**ARI-STOBU® -**

**Straight through with butt weld ends**

- TRB 801 Annex II No. 45
- EN ISO 15848-1 / TA - Luft (optional)  
TÜV-Test-No. TA 08 2016 C04

Forged steel  
**Fig. 005**

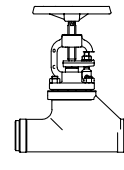

Page 6

**ARI-STOBU® -**

**Straight through with butt weld ends**

- TRB 801 Annex II No. 45
- EN ISO 15848-1 / TA - Luft (optional)  
TÜV-Test-No. TA 08 2016 C04

Cast steel  
**Fig. 005**

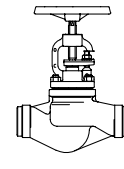

Page 7

**ARI-STOBU® -**

**Y-pattern with flanges**

- TRB 801 Annex II No. 45
- EN ISO 15848-1 / TA - Luft (optional)  
TÜV-Test-No. TA 08 2016 C04

Stainless steel  
**Fig. 009**

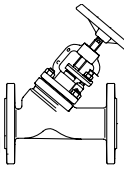

Page 8

**ARI-STOBU® -**

**Angle pattern with flanges**

- TRB 801 Annex II No. 45 (except EN-JL1040)
- EN ISO 15848-1 / TA - Luft (optional)  
TÜV-Test-No. TA 08 2016 C04

Grey cast iron  
SG iron  
**Fig. 007/307**

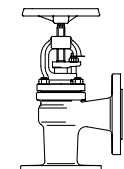

Page 9

**ARI-STOBU® -**

**Angle pattern with flanges**

- TRB 801 Annex II No. 45
- EN ISO 15848-1 / TA - Luft (optional)  
TÜV-Test-No. TA 08 2016 C04

Cast steel  
**Fig. 007/307**

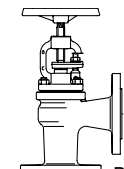

Page 10

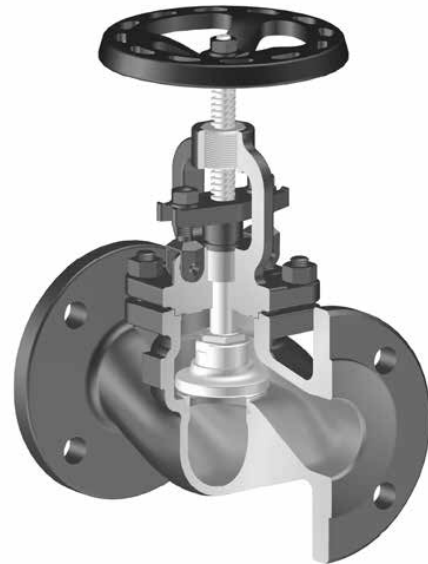

Fig. 006

**Features:**

- Proven technology
  - Solid plug made of stainless material
  - Solid stem made of stainless material
  - Solid seat made of stainless material
  - Stem with roll hardened thread
  - Burnished stem
  - High-tensile gland packing
  - Favourable zeta-values also for small nominal diameters
- In cast steel, forged steel and stainless steel:
- Bonnet top with threaded bushing
  - Flap-type screws

## Technical data

### Stop valve - straight through with flanges and gland seal (Grey cast iron, SG iron)

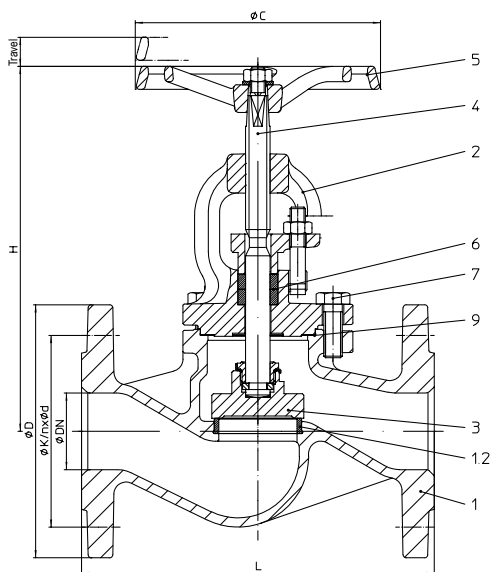

Figure	Nominal pressure	Material	Nominal diameter
12.006	PN16	EN-JL1040	DN15-300
12.306	PN16	EN-JL1040	DN15-300
22.006	PN16	EN-JS1049	DN15-350
22.306	PN16	EN-JS1049	DN15-350
23.006	PN25	EN-JS1049	DN15-150
23.306	PN25	EN-JS1049	DN15-150

**Fig. 306: Trim made of RG/MS:**  
 CuZn35Ni3Mn2AlPb, CW710R code number 02  
 CuSn10-Cu, CC480K code number 03  
 (max. operating temperature: 180°C, code number acc. to DIN 86251)

Test: • DN15-300 optional:  
 EN ISO 15848-1 / TA - Luft  
 TÜV-Test-No. TA 08 2016 C04 (refer to page 16)

Considered standards: • EN 13789 (EN-JL1040, EN-JS1049)

**At high differential pressures a balancing plug is necessary!**  
**(not possible at Fig. 306, observe max. differential pressure!)**  
 (refer to page 13)

Parts						
Pos.	Sp.p.	Description	Fig. 12.006	Fig. 12.306	Fig. 22./23.006	Fig. 22./23.306
1		Body	EN-JL1040, EN-GJL-250		EN-JS1049, EN-GJS-400-18U-LT	
1.2		Seat ring	X20Cr13+QT, 1.4021+QT	CuSn10-Cu, CC480K code number 03	X20Cr13+QT, 1.4021+QT	CuSn10-Cu, CC480K code number 03
2		Bonnet	EN-JL1040, EN-GJL-250		EN-JS1049, EN-GJS-400-18U-LT	
3	x	Plug	DN ≤200: X20Cr13+QT, 1.4021+QT DN >200: P265 GH, 1.0425	CuZn35Ni3Mn2AlPb, CW710R code number 02 CuSn10-Cu, CC480K code number 03	DN ≤200: X20Cr13+QT, 1.4021+QT DN >200: P265 GH, 1.0425	CuZn35Ni3Mn2AlPb, CW710R code number 02 CuSn10-Cu, CC480K code number 03
4	x	Stem	X20Cr13+QT, 1.4021+QT (burnished)	CuSn8, CW453K code number 03 (burnished)	X20Cr13+QT, 1.4021+QT (burnished)	CuSn8, CW453K code number 03 (burnished)
5		Handwheel	EN-JL1040, EN-GJL-250 (FE 13 Epoxid-coating)			
6	x	Packing ring	Pure graphite			
7		Hexagon bolt	5.6		--	
7		Stud	--		25CrMo4, 1.7218	
8		Hexagon nut	--		C35E, 1.1181	
9	x	Gasket	Pure graphite (CrNi laminated with graphite)			
L Spare parts						

DN	15	20	25	32	40	50	65	80	100	125	150	200	250	300	350
----	----	----	----	----	----	----	----	----	-----	-----	-----	-----	-----	-----	-----

Face-to-face dimension FTF series 1 according to DIN EN 558 Standard-flange dimensions refer to page 15

L (mm)	130	150	160	180	200	230	290	310	350	400	480	600	730	850	980
--------	-----	-----	-----	-----	-----	-----	-----	-----	-----	-----	-----	-----	-----	-----	-----

Dimensions																
H (mm)	185	185	205	205	230	230	270	305	355	395	450	570	685	770	860	
ØC (mm)	120	120	140	140	160	160	180	200	225	250	400	520	520	520	640	
Travel (mm)	9	9	13	13	21	19	28	32	36	52	56	73	80	110	116	
Kvs-value (m³/h)	4,2	7,4	12	19	31	47	77	120	188	288	410	725	1145	1635	2220	
Zeta-value	--	4,6	4,7	4,3	4,6	4,3	4,5	4,8	4,5	4,5	4,7	4,8	4,9	4,8	4,9	

Zeta-value ... range of tolerance for Kvs-values acc. to VDI/VDE 2173

Weights																
12.006 / 306 (kg)	3,5	4	5	6,8	9,3	12,2	18	24,5	35	55	77	145	243	341	--	
22.006 / 306 (kg)	3,9	4,3	5,4	7	9,5	12,9	18,4	24,5	36	56	78	122	247	336	451	
23.006 / 306 (kg)	3,9	4,3	5,4	7	9,5	12,9	18,4	24,5	36	56	78	--	--	--	--	

Information / restriction of technical rules need to be observed!

Operating and installation instructions can be downloaded at [www.ari-armaturen.com](http://www.ari-armaturen.com).

ARI-Valves of EN-JL1040 are not allowed to be operated in systems acc. to TRD 110.

A production permission acc. to TRB 801 No. 45 is available. (acc. to TRB 801 No. 45 EN-JL1040 is not allowed.)

The engineer, designing a system or a plant, is responsible for the selection of the correct valve.

Resistance and fitness must be verified, contact manufacturer for information (refer to Product overview and Resistance list).

## Technical data

### Stop valve - straight through with flanges and gland seal (Cast steel)

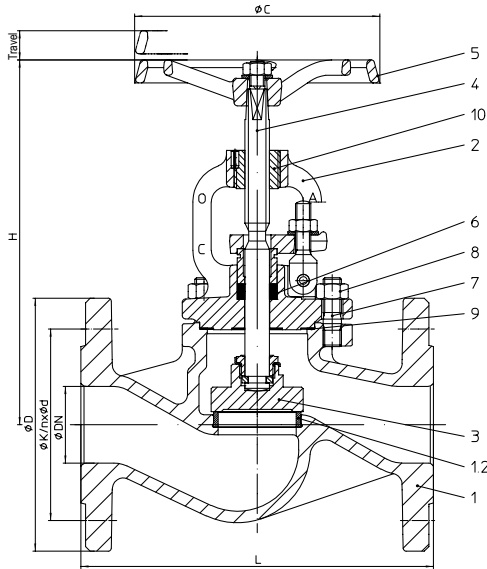

Figure	Nominal pressure	Material	Nominal diameter
34.006	PN25	1.0619+N	DN15-500
34.306	PN25	1.0619+N	DN15-500
35.006	PN40	1.0619+N	DN15-500
35.306	PN40	1.0619+N	DN15-500

#### Fig. 306: Trim made of RG/MS

CuZn35Ni3Mn2AlPb, CW710R code number 02

CuSn10-Cu, CC480K code number 03

(max. operating temperature: 180°C, code number acc. to DIN 86251)

#### Test:

• DN15-300 optional:  
EN ISO 15848-1 / TA - Luft  
TÜV-Test-No. TA 08 2016 C04 (refer to page 16)

#### Considered standards:

• EN 13709 (1.0619+N)

**At high differential pressures a balancing plug is necessary!**  
**(not possible at Fig. 306, observe max. differential pressure!)**  
(refer to page 13)

Parts				
Pos.	Sp.p.	Description	Fig. 34./35.006	Fig. 34./35.306
1		Body	GP240GH+N, 1.0619+N	
1.2		Seat ring	DN ≤50: X20Cr13+QT, 1.4021+QT DN >50: G19 9 Nb Si, 1.4551	CuSn10-Cu, CC480K code number 03
2		Bonnet	GP240GH+N, 1.0619+N	
3	x	Plug	DN ≤200: X20Cr13+QT, 1.4021+QT DN >200: P265 GH, 1.0425	CuZn35Ni3Mn2AlPb, CW710R code number 02 CuSn10-Cu, CC480K code number 03 <sup>2)</sup>
4	x	Stem	X20Cr13+QT, 1.4021+QT (burnished)	CuSn8, CW453K code number 03 (burnished)
5		Handwheel	EN-JL1040, EN-GJL-250 (FE 13 Epoxid-coating)	
6	x	Packing ring	Pure graphite	
7		Stud	25CrMo4, 1.7218	
8		Hexagon nut	C35E, 1.1181	
9	x	Gasket	Pure graphite (CrNi laminated with graphite)	
10		Insert nuts	11SMn30+C, 1.0715+C	
L Spare parts				

DN	15	20	25	32	40	50	65	80	100	125	150	200	250	300	350	400	500
----	----	----	----	----	----	----	----	----	-----	-----	-----	-----	-----	-----	-----	-----	-----

Face-to-face dimension FTF series 1 according to DIN EN 558																Standard-flange dimensions refer to page 15		
L	(mm)	130	150	160	180	200	230	290	310	350	400	480	600	730	850	980	1100	1350*

\* acc. to manufacturers standard

Dimensions																		
	(mm)	185	185	205	205	230	230	270	305	355	395	450	570	685	770	860	865	995
H	(mm)	120	120	140	140	160	160	180	200	225	250	400	520	520	520	640	640	640
ØC	(mm)	9	9	13	13	21	19	28	32	36	52	56	73	80	110	116	126	181
Travel	(mm)	4,2	7,4	12	19	31	47	77	120	188	288	410	725	1145	1635	2220	3180	4530
Kvs-value	(m <sup>3</sup> /h)	4,6	4,7	4,3	4,6	4,3	4,5	4,8	4,5	4,5	4,7	4,8	4,9	4,8	4,8	4,9	3,4	4,9
Zeta-value	--	Zeta-value ... range of tolerance for Kvs-values acc. to VDI/VDE 2173																

Weights																		
	(kg)	4,4	5,4	6,3	7	10,5	13,8	21	27,5	40	61	84	160	265	377	510	780	1095
34.006 / 306	(kg)	4,8	5,4	7,1	8	11,5	13,5	23,5	28	39,5	61	84	170	283	414	557	857	1150

Information / restriction of technical rules need to be observed!

Operating and installation instructions can be downloaded at [www.ari-armaturen.com](http://www.ari-armaturen.com).

A production permission acc. to TRB 801 No. 45 is available.

The engineer, designing a system or a plant, is responsible for the selection of the correct valve.

Resistance and fitness must be verified, contact manufacturer for information (refer to Product overview and Resistance list).

## Technical data

### Stop valve - straight through with flanges and gland seal (Forged steel)

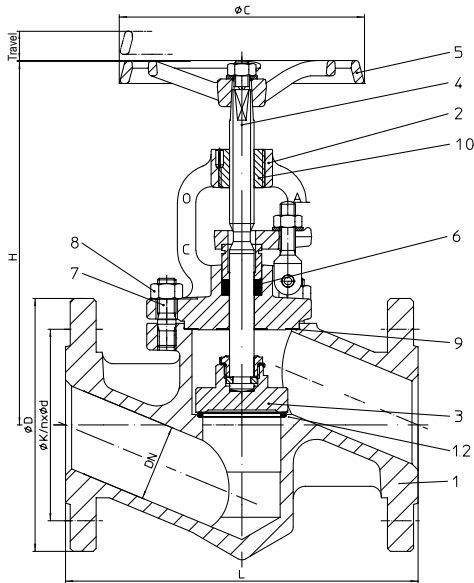

Figure	Nominal pressure	Material	Nominal diameter
45.006	PN40	1.0460 / 1.0619+N	DN15-50
Test:	• optional: EN ISO 15848-1 / TA - Luft TÜV-Test-No. TA 08 2016 C04 (refer to page 16)		
Considered standards:	• EN 13709 (1.0460, 1.0619+N)		

Parts			
Pos.	Sp.p.	Description	Fig. 45.006
1		Body	P250 GH, 1.0460
1.2		Seat ring	G19 9 Nb Si, 1.4551
2		Bonnet	1.0619+N
3	x	Plug	X20Cr13+QT, 1.4021+QT
4	x	Stem	X20Cr13+QT, 1.4021+QT (burnished)
5		Handwheel	EN-JL1040, EN-GJL-250 (FE 13 Epoxid-coating)
6	x	Packing ring	Pure graphite
7		Stud	25CrMo4, 1.7218
8		Hexagon nut	C35E, 1.1181
9	x	Gasket	Pure graphite (CrNi laminated with graphite)
10		Insert nuts	11SMn30+C, 1.0715+C
L Spare parts			

DN	15	20	25	32	40	50
----	----	----	----	----	----	----

Face-to-face dimension FTF series 1 according to DIN EN 558							Standard-flange dimensions refer to page 15
L	(mm)	130	150	160	180	200	230

Dimensions							
H	(mm)	201	203	223	229	236	237
ØC	(mm)	120	120	140	140	160	160
Travel	(mm)	9	9	13	13	21	19
Kvs-value	(m³/h)	3,3	5,8	9,2	15	23,3	36
Zeta-value	--	7,4	7,6	7,4	7,4	7,5	7,7
Zeta-value ... range of tolerance for Kvs-values acc. to VDI/VDE 2173							

Dimensions							
45.006	(kg)	4,3	5	6	7	10	13

Information / restriction of technical rules need to be observed!

Operating and installation instructions can be downloaded at [www.ari-armaturen.com](http://www.ari-armaturen.com).

A production permission acc. to TRB 801 No. 45 is available.

The engineer, designing a system or a plant, is responsible for the selection of the correct valve.

Resistance and fitness must be verified, contact manufacturer for information (refer to Product overview and Resistance list).

**Technical data**

**Stop valve - straight through with flanges and gland seal (Stainless steel)**

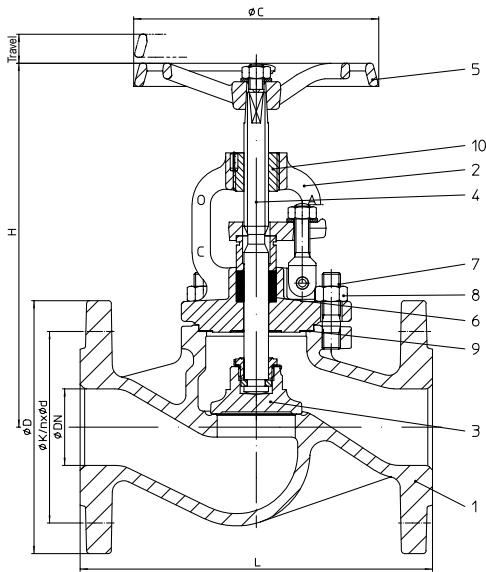

Figure	Nominal pressure	Material	Nominal diameter
52.006	PN16	1.4408	DN15-200
54.006	PN25	1.4408	DN200
55.006	PN40	1.4408	DN15-150

Test:	<ul style="list-style-type: none"> <li>• optional: EN ISO 15848-1 / TA - Luft TÜV-Test-No. TA 08 2016 C04 (refer to page 16)</li> </ul>
-------	---

Considered standards:	<ul style="list-style-type: none"> <li>• EN 13709 (1.4408)</li> </ul>
-----------------------	---

**At high differential pressures a balancing plug is necessary!**  
(refer to page 13)

Parts			
Pos.	Sp.p.	Description	Fig. 52./54./55.006
1		Body	GX5CrNiMo19-11-2, 1.4408
2		Bonnet	GX5CrNiMo19-11-2, 1.4408
3	x	Plug	X6CrNiMoTi17-12-2, 1.4571
4	x	Stem	X6CrNiMoTi17-12-2, 1.4571
5		Handwheel	EN-JL 1040, EN-GJL-250 (FE 13 Epoxid-coating)
6	x	Packing ring	Pure graphite
7		Stud	A4-70
8		Hexagon nut	A4
9	x	Gasket	Pure graphite (CrNi laminated with graphite)
10		Insert nuts	X5CrNiMo17-12-2, 1.4401
L Spare parts			

DN	15	20	25	32	40	50	65	80	100	125	150	200
----	----	----	----	----	----	----	----	----	-----	-----	-----	-----

Face-to-face dimension FTF series 1 according to DIN EN 558													Standard-flange dimensions refer to page 15	
L	(mm)	130	150	160	180	200	230	290	310	350	400	480	600	

Dimensions													
H	(mm)	185	185	205	205	230	230	270	305	355	395	450	570
ØC	(mm)	120	120	140	140	160	160	180	200	225	250	400	520
Travel	(mm)	9	9	13	13	21	19	28	32	36	52	56	73
Kvs-value	(m³/h)	4,2	7,4	12	19	31	47	77	120	188	288	410	725
Zeta-value	--	4,6	4,7	4,3	4,6	4,3	4,5	4,8	4,5	4,5	4,7	4,8	4,9

Zeta-value ... range of tolerance for Kvs-values acc. to VDI/VDE 2173

Dimensions													
52./54./55.006	(kg)	4,8	5,4	7,1	8	11,5	13,5	23,5	28	39,5	61	84	170

Information / restriction of technical rules need to be observed!

Operating and installation instructions can be downloaded at [www.ari-armaturen.com](http://www.ari-armaturen.com).

A production permission acc. to TRB 801 No. 45 is available.

The engineer, designing a system or a plant, is responsible for the selection of the correct valve.

Resistance and fitness must be verified, contact manufacturer for information (refer to Product overview and Resistance list).

## Technical data

### Stop valve - straight through with butt weld ends and gland seal (Forged steel)

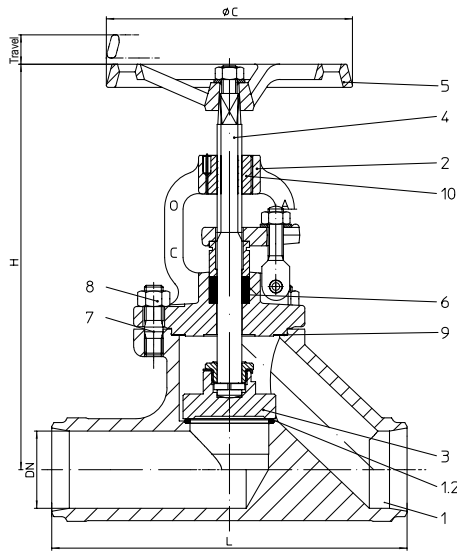

Figure	Nominal pressure	Material	Nominal diameter
45.005	PN40	1.0460 / 1.0619+N	DN15-50
DN65-300 refer to Fig. 35.005 (1.0619+N)			

Butt weld ends according to DIN EN 12627 Fig. 4 (refer to page 12)

Test: • optional:  
EN ISO 15848-1 / TA - Luft  
TÜV-Test-No. TA 08 2016 C04 (refer to page 16)

Considered standards: • EN 13709 (1.0460, 1.0619+N)

Parts			
Pos.	Sp.p.	Description	Fig. 45.005
1		Body	P250 GH, 1.0460
1.2		Seat ring	G19 9 Nb Si, 1.4551
2		Bonnet	1.0619+N
3	x	Plug	X20Cr13+QT, 1.4021+QT
4	x	Stem	X20Cr13+QT, 1.4021+QT (burnished)
5		Handwheel	EN-JL1040, EN-GJL-250 (FE 13 Epoxid-coating)
6	x	Packing ring	Pure graphite
7		Stud	25CrMo4, 1.7218
8		Hexagon nut	C35E, 1.1181
9	x	Gasket	Pure graphite (CrNi laminated with graphite)
10		Insert nuts	11SMn30+C, 1.0715+C
L Spare parts			

DN	15	20	25	32	40	50
----	----	----	----	----	----	----

Face-to-face dimension ETE series 1 according to DIN EN 12982							
L	(mm)	130	150	160	180	200	230

Dimensions							
H	(mm)	205	205	225	230	235	235
ØC	(mm)	120	120	140	140	160	160
Travel	(mm)	9	9	13	13	21	19
Kvs-value	(m³/h)	3,3	5,8	9,2	15	23,3	36
Zeta-value	--	4,6	4,7	4,3	4,6	4,3	4,5
Zeta-value ... range of tolerance for Kvs-values acc. to VDI/VDE 2173							

Weights							
45.005	(kg)	2,9	3	3,5	3,5	6,2	7,8

Information / restriction of technical rules need to be observed!

Operating and installation instructions can be downloaded at [www.ari-armaturen.com](http://www.ari-armaturen.com).

A production permission acc. to TRB 801 No. 45 is available.

The engineer, designing a system or a plant, is responsible for the selection of the correct valve.

Resistance and fitness must be verified, contact manufacturer for information (refer to Product overview and Resistance list).

**Technical data**

**Stop valve - straight through with butt weld ends and gland seal (Cast steel)**

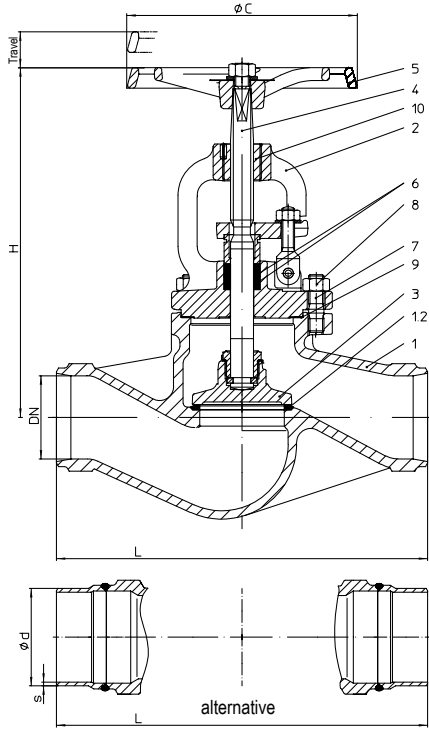

Figure	Nominal pressure	Material	Nominal diameter
35.005	PN40	1.0619+N	DN65-300
DN15-50 refer to Fig. 45.005 (1.0460)			

**Butt weld ends according to DIN EN 12627 Fig. 4 (refer to page 12)**  
 alternative: DN 65-200 with shoed ends of P235GH

Test:	• optional: EN ISO 15848-1 / TA - Luft TÜV-Test-No. TA 08 2016 C04 (refer to page 16)
-------	---

Considered standards:	• EN 13709 (1.0619+N)
-----------------------	-----------------------

**At high differential pressures a balancing plug is necessary!**  
 (refer to page 13)

Parts			
Pos.	Sp.p.	Description	Fig. 35.005
1		Body	GP240GH+N, 1.0619+N
1.2		Seat ring	G19 9 Nb Si, 1.4551
2		Bonnet	GP240GH+N, 1.0619+N
3	x	Plug	DN ≤200: X20Cr13+QT, 1.4021+QT DN >200: P265 GH, 1.0425
4	x	Stem	X20Cr13+QT, 1.4021+QT (burnished)
5		Handwheel	EN-JL1040, EN-GJL-250 (FE 13 Epoxid-coating)
6	x	Packing ring	Pure graphite
7		Stud	25CrMo4, 1.7218
8		Hexagon nut	C35E, 1.1181
9	x	Gasket	Pure graphite (CrNi laminated with graphite)
10		Insert nuts	11SMn30+C, 1.0715+C
L Spare parts			

DN	65	80	100	125	150	200	250	300
----	----	----	-----	-----	-----	-----	-----	-----

Face-to-face dimension ETE series 1 according to DIN EN 12982									
L	(mm)	290	310	350	400	480	600	730	850

Dimensions									
H	(mm)	270	305	355	395	450	570	685	770
ØC	(mm)	180	200	225	250	400	520	520	520
Travel	(mm)	28	32	36	52	56	73	80	110
Kvs-value	(m³/h)	77	120	188	288	410	725	1145	1635
Zeta-value	--	4,8	4,5	4,5	4,7	4,8	4,9	4,8	4,8

Zeta-value ... range of tolerance for Kvs-values acc. to VDI/VDE 2173

Weights									
35.005	(kg)	16	21	28	45	66	143	228	345

Information / restriction of technical rules need to be observed!

Operating and installation instructions can be downloaded at [www.ari-armaturen.com](http://www.ari-armaturen.com).

A production permission acc. to TRB 801 No. 45 is available.

The engineer, designing a system or a plant, is responsible for the selection of the correct valve.

Resistance and fitness must be verified, contact manufacturer for information (refer to Product overview and Resistance list).

## Technical data

### Stop valve - Y-pattern with flanges and gland seal (Stainless steel)

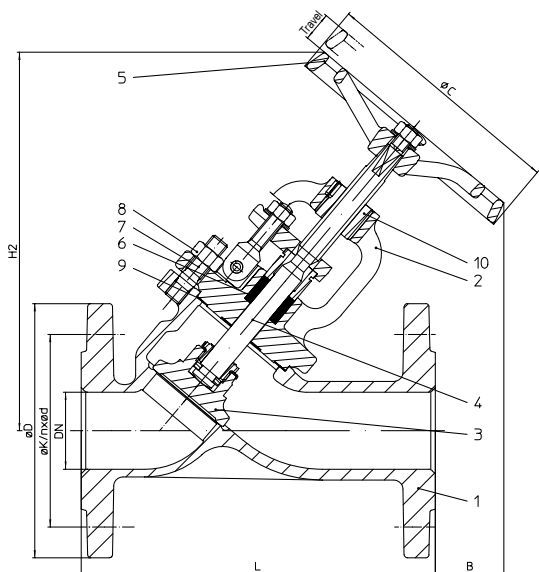

Figure	Nominal pressure	Material	Nominal diameter
52.009	PN16	1.4408	DN15-200
54.009	PN25	1.4408	DN15-200
55.009	PN40	1.4408	DN15-200

Test:	<ul style="list-style-type: none"> <li>• optional:</li> <li>EN ISO 15848-1 / TA - Luft</li> <li>TÜV-Test-No. TA 08 2016 C04 (refer to page 16)</li> </ul>
-------	---

Considered standards:	<ul style="list-style-type: none"> <li>• EN 13709 (1.4408)</li> </ul>
-----------------------	---

**At high differential pressures a balancing plug is necessary!**  
(refer to page 13)

Parts			
Pos.	Sp.p.	Description	Fig. 52./54./55.009
1		Body	GX5CrNiMo19-11-2, 1.4408
2		Bonnet	GX5CrNiMo19-11-2, 1.4408
3	x	Plug	X6CrNiMoTi17-12-2, 1.4571
4	x	Stem	X6CrNiMoTi17-12-2, 1.4571
5		Handwheel	EN-JL1040, EN-GJL-250 (FE 13 Epoxid-coating)
6	x	Packing ring	Pure graphite
7		Stud	A4-70
8		Hexagon nut	A4
9	x	Gasket	Pure graphite (CrNi laminated with graphite)
10		Insert nuts	X5CrNiMo17-12-2, 1.4401
L Spare parts			

DN	15	20	25	32	40	50	65	80	100	125	150	200
----	----	----	----	----	----	----	----	----	-----	-----	-----	-----

Face-to-face dimension FTF series 1 according to DIN EN 558											Standard-flange dimensions refer to page 15		
L	(mm)	130	150	160	180	200	230	290	310	350	400	480	600

Dimensions													
H2	(mm)	200	200	225	225	245	250	285	320	415	435	505	640
B	(mm)	80	70	85	70	70	45	30	65	75	80	75	130
ØC	(mm)	120	120	140	140	160	160	180	200	225	250	400	520
Travel	(mm)	9	9	13	13	21	19	28	32	36	52	56	73
Kvs-value	(m³/h)	5,8	8,6	13	20	42	59	90	127	205	310	445	800
Zeta-value	--	2,4	3,5	3,7	4,2	2,3	2,9	3,5	4,1	3,8	4,1	4,1	5

Zeta-value ... range of tolerance for Kvs-values acc. to VDI/VDE 2173

Weights													
52./54./55.009	(kg)	4	4,6	6	7,6	9,4	11,6	16,5	23,2	35	43	72	141

Information / restriction of technical rules need to be observed!

Operating and installation instructions can be downloaded at [www.ari-armaturen.com](http://www.ari-armaturen.com).

A production permission acc. to TRB 801 No. 45 is available.

The engineer, designing a system or a plant, is responsible for the selection of the correct valve.

Resistance and fitness must be verified, contact manufacturer for information (refer to Product overview and Resistance list).



## Technical data

### Stop valve - angle pattern with flanges and gland seal (Grey cast iron, SG iron)

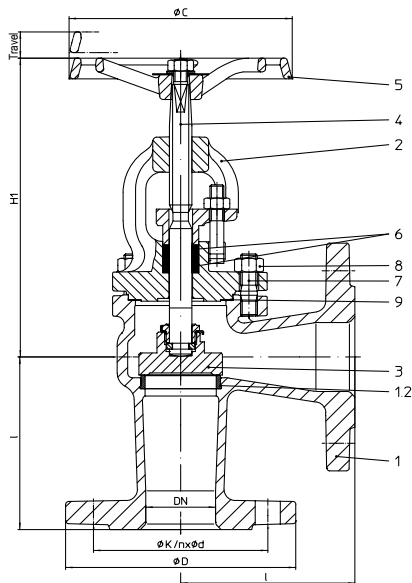

Figure	Nominal pressure	Material	Nominal diameter
12.007	PN16	EN-JL1040	DN15-300
12.307	PN16	EN-JL1040	DN15-300
22.007	PN16	EN-JS1049	DN15-500
22.307	PN16	EN-JS1049	DN15-500

**Fig. 307: Trim made of RG/MS**  
 CuZn35Ni3Mn2AlPb, CW710R code number 02  
 CuSn10-Cu, CC480K code number 03  
 (max. operating temperature: 180°C, code number acc. to DIN 86251)

Test: • DN15-300 optional:  
 EN ISO 15848-1 / TA - Luft  
 TÜV-Test-No. TA 08 2016 C04 (refer to page 16)

Considered standards: • EN 13789 (EN-JL1040, EN-JS1049)

**At high differential pressures a balancing plug is necessary!**  
**(not possible at Fig. 307, observe max. differential pressure!)**  
 (refer to page 13)

Parts						
Pos.	Sp.p.	Description	Fig. 12.007	Fig. 12.307	Fig. 22.007	Fig. 22.307
1		Body	EN-JL1040, EN-GJL-250		EN-JS1049, EN-GJS-400-18U-LT	
1.2		Seat ring	X20Cr13+QT, 1.4021+QT	CuSn10-Cu, CC480K code number 03	X20Cr13+QT, 1.4021+QT	CuSn10-Cu, CC480K code number 03
2		Bonnet	EN-JL1040, EN-GJL-250		EN-JS1049, EN-GJS-400-18U-LT	
3	x	Plug	DN ≤200: X20Cr13+QT, 1.4021+QT DN >200: P265 GH, 1.0425	CuZn35Ni3Mn2AlPb, CW710R code number 02 CuSn10-Cu, CC480K code number 03	DN ≤200: X20Cr13+QT, 1.4021+QT DN >200: P265 GH, 1.0425	CuZn35Ni3Mn2AlPb, CW710R code number 02 CuSn10-Cu, CC480K code number 03
4	x	Stem	X20Cr13+QT, 1.4021+QT (burnished)	CuSn8, CW453K code number 03 (burnished)	X20Cr13+QT, 1.4021+QT (burnished)	CuSn8, CW453K code number 03 (burnished)
5		Handwheel	EN-JL1040, EN-GJL-250 (FE 13 Epoxid-coating)			
6	x	Packing ring	Pure graphite			
7		Hexagon bolt	5.6		--	
7		Stud	--		25CrMo4, 1.7218	
8		Hexagon nut	--		C35E, 1.1181	
9	x	Gasket	Pure graphite (CrNi laminated with graphite)			
		L Spare parts				

DN	15	20	25	32	40	50	65	80	100	125	150	200	250	300	350	400	500
----	----	----	----	----	----	----	----	----	-----	-----	-----	-----	-----	-----	-----	-----	-----

Face-to-face dimension CTF series 8 according to DIN EN 558																	Standard-flange dimensions refer to page 15					
l	(mm)	90	95	100	105	115	125	145	155	175	200	225	275	325	375	425	475	525 *				
																			* acc. to manufacturers standard			

Dimensions																		
H1	(mm)	185	185	200	200	215	215	245	280	320	360	415	495	575	655	735	740	840
ØC	(mm)	120	120	140	140	160	160	180	200	225	250	400	520	520	520	640	640	640
Travel	(mm)	9	9	13	13	21	19	28	32	36	52	56	73	80	110	116	126	181
Kvs-value	(m³/h)	5,2	9,2	15	24	37	58	96	150	235	360	510	905	1430	2040	2775	3975	5660
Zeta-value	--	3	3	2,8	2,9	3	3	3,1	2,9	2,9	3	3,1	3,1	3,1	3,1	3,1	2,6	3,1
Zeta-value ... range of tolerance for Kvs-values acc. to VDI/VDE 2173																		

Weights																		
12.007 / 307	(kg)	3,9	4,5	5,5	6,6	9,1	11,5	17,1	22,4	32	46	67	126	184	270	--	--	--
22.007 / 307	(kg)	4	4,5	5,6	6,6	9,2	11,6	17	22,6	33	46	68	100	204	270	398	570	885

Information / restriction of technical rules need to be observed!

Operating and installation instructions can be downloaded at [www.ari-armaturen.com](http://www.ari-armaturen.com).

ARI-Valves of EN-JL1040 are not allowed to be operated in systems acc. to TRD 110.

A production permission acc. to TRB 801 No. 45 is available. (acc. to TRB 801 No. 45 EN-JL1040 is not allowed.)

The engineer, designing a system or a plant, is responsible for the selection of the correct valve.

Resistance and fitness must be verified, contact manufacturer for information (refer to Product overview and Resistance list).

## Technical data

### Stop valve - angle pattern with flanges and gland seal (Cast steel)

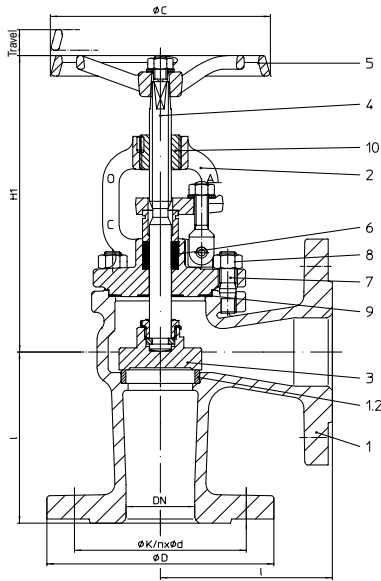

Figure	Nominal pressure	Material	Nominal diameter
34.007	PN25	1.0619+N	DN15-500
34.307	PN25	1.0619+N	DN15-500
35.007	PN40	1.0619+N	DN15-500
35.307	PN40	1.0619+N	DN15-500

#### Fig. 307: Trim made of RG/MS

CuZn35Ni3Mn2AlPb, CW710R code number 02  
 CuSn10-Cu, CC480K code number 03  
 (max. operating temperature: 180°C, code number acc. to DIN 86251)

Test: • DN15-300 optional:  
 EN ISO 15848-1 / TA - Luft  
 TÜV-Test-No. TA 08 2016 C04 (refer to page 16)

Considered standards: • EN 13709 (1.0619+N)

**At high differential pressures a balancing plug is necessary!  
 (not possible at Fig. 307, observe max. differential pressure!)  
 (refer to page 13)**

Parts				Fig. 34./35.007	Fig. 34./35.307
Pos.	Sp.p.	Description			
1		Body	GP240GH+N, 1.0619+N		
1.2		Seat ring	DN ≤50: X20Cr13+QT, 1.4021+QT DN >50: G19 9 Nb Si, 1.4551		CuSn10-Cu, CC480K code number 03
2		Bonnet	GP240GH+N, 1.0619+N		
3	x	Plug	DN ≤200: X20Cr13+QT, 1.4021+QT DN >200: P265 GH, 1.0425		CuZn35Ni3Mn2AlPb, CW710R code number 02 CuSn10-Cu, CC480K code number 03
4	x	Stem	X20Cr13+QT, 1.4021+QT (burnished)		CuSn8, CW453K code number 03 (burnished)
5		Handwheel	EN-JL1040, EN-GJL-250 (FE 13 Epoxid-coating)		
6	x	Packing ring	Pure graphite		
7		Stud	25CrMo4, 1.7218		
8		Hexagon nut	C35E, 1.1181		
9	x	Gasket	Pure graphite (CrNi laminated with graphite)		
10		Insert nuts	11SMn30+C, 1.0715+C		
L Spare parts					

DN	15	20	25	32	40	50	65	80	100	125	150	200	250	300	350	400	500
----	----	----	----	----	----	----	----	----	-----	-----	-----	-----	-----	-----	-----	-----	-----

#### Face-to-face dimension CTF series 8 according to DIN EN 558

l	(mm)	Standard-flange dimensions refer to page 15															
		90	95	100	105	115	125	145	155	175	200	225	275	325	375	425	475
		* acc. to manufacturers standard															

Dimensions																		
H1	(mm)	185	185	200	200	215	215	245	280	320	360	415	495	575	655	735	740	840
ØC	(mm)	120	120	140	140	160	160	180	200	225	250	400	520	520	520	640	640	640
Travel	(mm)	9	9	13	13	21	19	28	32	36	52	56	73	80	110	116	126	181
Kvs-value	(m³/h)	5,2	9,2	15	24	37	58	96	150	235	360	510	905	1430	2040	2775	3975	5660
Zeta-value	--	3	3	2,8	2,9	3	3	3,1	2,9	2,9	3	3,1	3,1	3,1	3,1	3,1	2,6	3,1
Zeta-value ... range of tolerance for Kvs-values acc. to VDI/VDE 2173																		

Weights																		
34.007 / 307	(kg)	5,2	7,2	7,4	8,4	12,4	13,6	20	25	34	53	70	138	170	290	383	690	963
35.007 / 307	(kg)	5,2	7,2	7,4	8,4	12,4	13,6	20	25	34	53	70	148	188	327	430	767	1018

Information / restriction of technical rules need to be observed!

Operating and installation instructions can be downloaded at [www.ari-armaturen.com](http://www.ari-armaturen.com).

A production permission acc. to TRB 801 No. 45 is available.

The engineer, designing a system or a plant, is responsible for the selection of the correct valve.

Resistance and fitness must be verified, contact manufacturer for information (refer to Product overview and Resistance list).

## Valves with butt weld ends

L = Face-to-face dimension  
Edge shaping acc. to DIN EN 25817

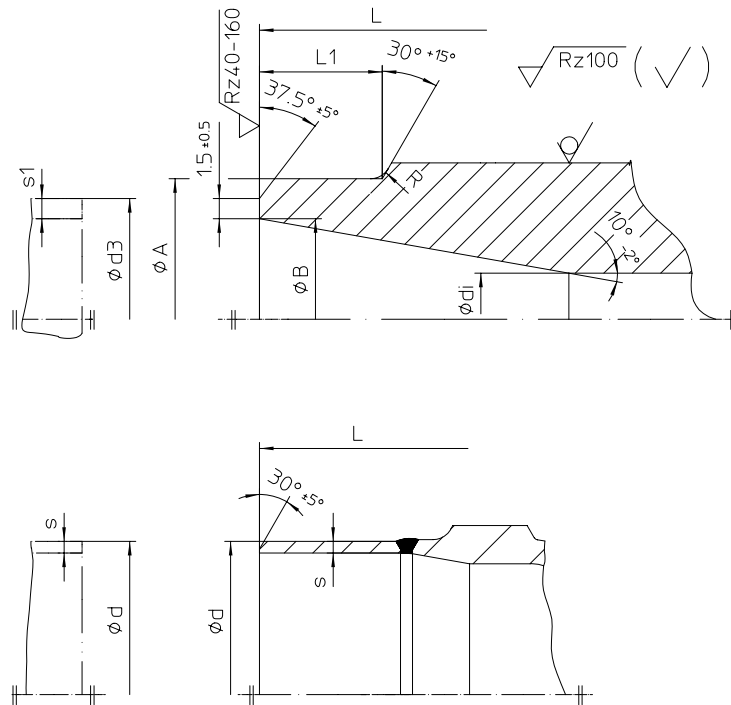

DN	15	20	25	32	40	50	65	80	100	125	150	200	250	300	350	400
----	----	----	----	----	----	----	----	----	-----	-----	-----	-----	-----	-----	-----	-----

Butt weld ends acc. to DIN EN 12627																	
L	(mm)	130	150	160	180	200	230	290	310	350	400	480	600	730	850	980	1100
ØA	(mm)	22	28	35	44	50	62	77	91	117	144	172	223	278	329	362	413
ØB	(mm)	17,3	22,3	28,5	37,2	43,1	53,9	68,9	80,9	104,3	130,7	157,1	204,9	257	307,9	338	384,4
Ødi	(mm)	15	20	25	32	40	50	65	80	100	125	150	200	250	300	330	375
R	(mm)	3	3	3	3	3	3	3	3	3	3	3	5	5	5	5	5
L1 (similar)	(mm)	10	10	10	10	10	10	10	12	14	18	20	20	25	33	45	45
Ød3	(mm)	21,3	26,9	33,7	42,4	48,3	60,3	76,1	88,9	114,3	139,7	168,3	219,1	273,0	323,9	355,6	406,4
s1	(mm)	2	2,3	2,6	2,6	2,6	3,2	3,6	4	5	4,5	5,6	7,1	8	8	8,8	11

Face-to-face dimension ETE series 1 according to DIN EN 12982

Butt weld ends according to DIN EN 12627 Fig. 4

Weld joint according to DIN EN 29692 code number 1.3.3

The material used for ARI valves with butt weld ends are:  
GP240GH+N, 1.0619+N acc. to DIN EN 10213-2,  
P250GH, 1.0460 acc. to DIN EN 10222-2.

DN	15	20	25	32	40	50	65	80	100	125	150	200	250	300	350	400
----	----	----	----	----	----	----	----	----	-----	-----	-----	-----	-----	-----	-----	-----

Shoed ends made of P235GH (Pipe connection ≙ welding neck flanges)																
Ød	(mm)	--	--	--	--	--	76,1	88,9	114,3	139,7	168,3	219,1	--	--	--	--
Øs	(mm)	--	--	--	--	--	2,9	3,2	3,6	4,0	4,5	6,3	--	--	--	--

The material used for ARI valves with shoed ends (DN 65-200) P235GH according to DIN EN 10216-2.

Based on our experience we recommend electric welding process for connecting valves or strainers with tubes or with each other.

Lime based electrodes with an appropriate composite material should be used as filler material for welding.

Gas welding should be avoided.

Because of the different material compositions and wall thickness of the steam traps and the pipe gas welding shall not be applied. Quenching cracks and coarse grain structure may develop.

## Plug design

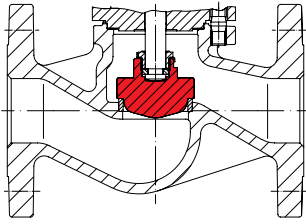

Regulating plug  
(for max. permissible  $\Delta P$  refer to Flow diagram)

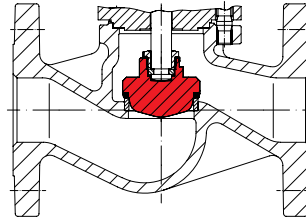

Regulating plug with soft seal  
Max. operating temperature 200°C at PTFE + 25% carbon  
(for max. permissible  $\Delta P$  refer to Flow diagram)

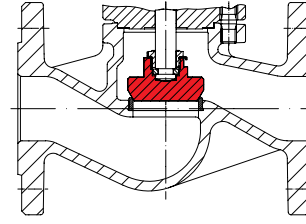

Plug with marginal seat

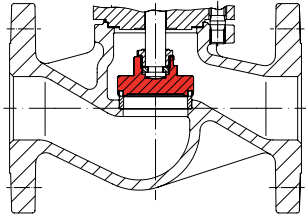

Plug with Soft seal  
Max. operating temperature 200°C at PTFE + 25% carbon

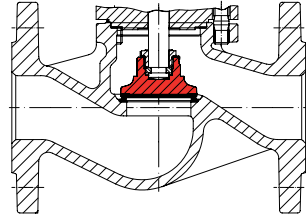

Stellited plug

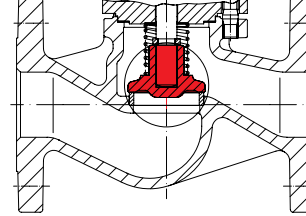

Screw down non-return plug with re-setting spring -  
max. differential pressure, refer to table of pressure  
balancing plugs,  
Set pressure 0,1 bar  
(Design for special applications refer to page 14)  
Flow values (Kvs and Zeta) refer to data sheet „Check valves“.

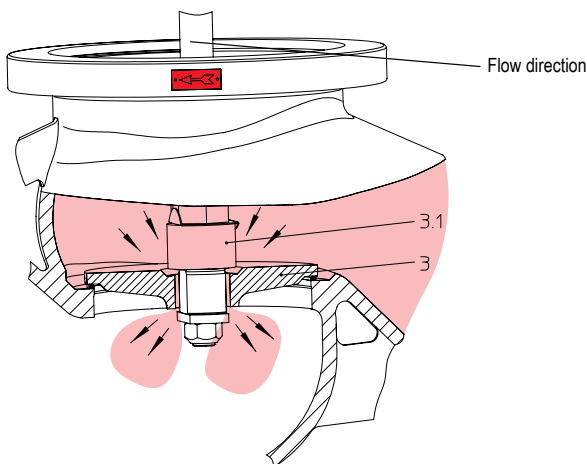

Valves with balancing plugs have to be installed with medium **flowing over the plug (3)** as indicated by flow direction arrow on valve body.

Working principles:

When the valve is closed, anticlockwise rotation of the hand wheel lifts the pilot plug (3.1) off the larger balancing plug (3).

This allows the medium to pass through the plug and equalizes the pressure of the medium under the plug (3). After the pressures have been equalized within the values stated in the table, the valve can be opened by turning the valve further with normal manual force.

Balancing plugs are fully effective only in closed systems.

The pressures of the medium on either side of the plug can not be equalized if the medium is discharged into open air.

A bypass line or some other arrangement is necessary if too much time is required for pressure equalization owing to the volume in the piping system.

Balancing plug

ARI-stop valves with differential pressures exceeding the following pressures, have to be fitted with pressure balancing plugs

DN	125	150	200	250	300	350	400	500
Differential pressure ( $\Delta P$ ) (bar)	25	21	14	9	6	4,5	3,5	1,5

Special design / Accessories

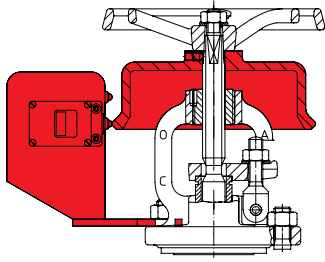

Limit switch

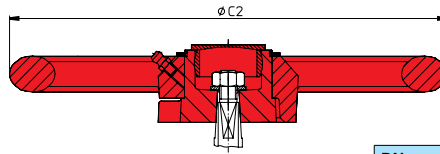

Handwheel operated by impact force

DN (mm)	ØC2 (mm)	Weight (kg)
15-32	180	1,5
40-100	250	3
125-200	365	5
250-500	520	13

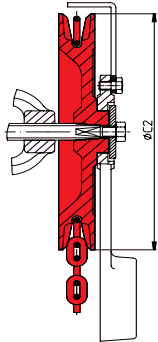

Chain wheel

DN (mm)	ØC2 (mm)	Weight (kg)
15-32	180	2,5
40-80	220	7
100-150	260	8,9
200-400	300	11

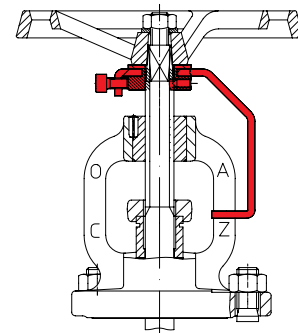

Position indicator with locking device

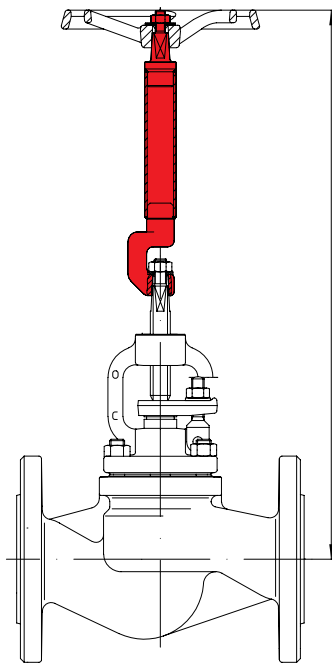

Stem extension (please specify height in your order)

Flow direction

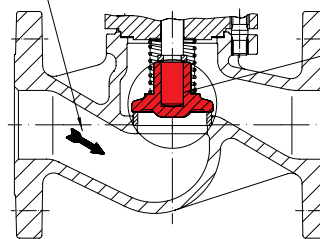

Hole and stem with a precise tolerance

**Screw down non-return plug with re-setting spring and plug damper**

In special applications, like high flow turbulences, stuffing box valves with damper should be used with execution „screw down non-return plug“:

- if stuffing box valves with loose plug are mounted directly by centrifuged pumps;
- behind pressure reduction stations;
- behind pipe elbows;
- in compact plants;
- if expansion joints are missing;
- if the pump is not mounted on a damper;
- if there is no flow stabilizing pipe dimension;
- if there is no start-up bypass line;
- when chosen valve diameter to large.

**Working principle**

The precise tolerance between stem and plug hole prevents an abrupt displacement of medium out of the plug.

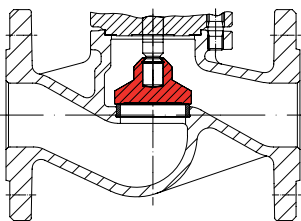

DN15-50

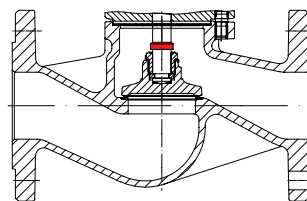

DN ≥ 65

Back seat

## Flange dimensions / Pressure-temperature-ratings

DN		15	20	25	32	40	50	65	80	100	125	150	200	250	300	350	400	500	
<b>Standard-flange dimensions</b>		Flanges acc. to DIN EN 1092-1/-2 (Flange holes / -thickness tolerances acc. to DIN 2533/2544/2545)																	
PN6	ØD	(mm)	80	90	100	120	130	140	160	190	210	240	265	320	--	--	--	--	--
	ØK	(mm)	55	65	75	90	100	110	130	150	170	200	225	280	--	--	--	--	--
	n x Ød	(mm)	4x11	4x11	4x11	4x14	4x14	4x14	4x14	4x18	4x18	8x18	8x18	8x18	--	--	--	--	--
PN16	ØD	(mm)	95	105	115	140	150	165	185	200	220	250	285	340	405	460	520	580	715
	ØK	(mm)	65	75	85	100	110	125	145	160	180	210	240	295	355	410	470	525	650
	n x Ød	(mm)	4x14	4x14	4x14	4x18	4x18	4x18	4x18 <sup>1)</sup>	8x18	8x18	8x18	8x22	12x22	12x26	12x26	16x26	16x30	20x33
PN25	ØD	(mm)	95	105	115	140	150	165	185	200	235	270	300	360	425	485	555	620	730
	ØK	(mm)	65	75	85	100	110	125	145	160	190	220	250	310	370	430	490	550	660
	n x Ød	(mm)	4x14	4x14	4x14	4x18	4x18	4x18	8x18	8x18	8x22	8x26	8x26	12x26	12x30	16x30	16x33	16x36	20x36
PN40	ØD	(mm)	95	105	115	140	150	165	185	200	235	270	300	375	450	515	580	660	755
	ØK	(mm)	65	75	85	100	110	125	145	160	190	220	250	320	385	480	510	585	670
	n x Ød	(mm)	4x14	4x14	4x14	4x18	4x18	4x18	8x18	8x18	8x22	8x26	8x26	12x30	12x33	16x33	16x36	16x39	20x42

<sup>1)</sup> also with 8 bore holes acc. to DIN EN 1092-1/-2 possible.

<b>Pressure-temperature-ratings</b>	Intermediate values for max. permissible operational pressures can be determined by linear interpolation of the given temperature / pressure chart.
-------------------------------------	---

acc. to DIN EN 1092-2			-60°C to <-10°C <sup>1)</sup>	-10°C to 120°C	150°C	200°C	250°C	300°C	350°C	400°C	450°C
EN-JL1040	16	(bar)	--	16	14,4	12,8	11,2	9,6	--	--	--
EN-JS1049	16	(bar)	on request	16	15,5	14,7	13,9	12,8	11,2	--	--
EN-JS1049	25	(bar)	on request	25	24,3	23	21,8	20	17,5	--	--

acc. to manufacturers standard			-60°C to <-10°C <sup>1)</sup>	-10°C to 120°C	150°C	200°C	250°C	300°C	350°C	400°C	450°C
1.0619+N	25	(bar)	18,7	25	23,9	22	20	17,2	16	14,8	8,2
1.0619+N	40	(bar)	30	40	38,1	35	32	28	25,7	23,8	13,1
1.0460	25	(bar)	18,7	25	23,9	22	20	17,2	16	14,8	10
1.0460	40	(bar)	30	40	38,1	35	32	28	25,7	23,8	16

acc. to DIN EN 1092-1			-60°C to <-10°C <sup>1)</sup>	-10°C to 100°C	150°C	200°C	250°C	300°C	350°C	400°C	450°C
1.4408	16	(bar)	16	16	14,5	13,4	12,7	11,8	11,4	10,9	--
1.4408	25	(bar)	25	25	22,7	21	19,8	18,5	17,8	17,1	--
1.4408	40	(bar)	40	40	36,3	33,7	31,8	29,7	28,5	27,4	--

<sup>1)</sup> Studs and nuts made of A4-70 (at temperatures below -10°C)

### Please indicate when ordering:

- Figure-No.
- Nominal pressure
- Nominal diameter
- Special design / accessories

### Example:

Figure 35.006; Nominal pressure PN40; Nominal diameter DN100; with regulating plug, position indicator with locking device.

Test EN ISO 15848-1 / TA - Luft

Test: DN15-300 optional  
EN ISO 15848-1 / TA - Luft TÜV-Test-No. TA 08 2016 C04

with spring-loaded stuffing box

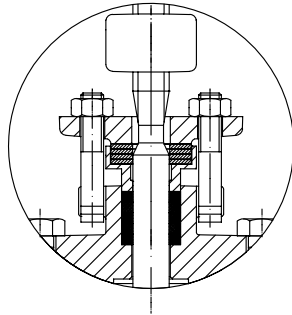

Grey cast iron, SG iron

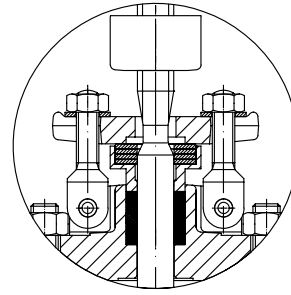

Cast steel, Forged steel, Stainless steel