

Technical data sheet

Non return valve

Applications and special features



- Can be installed horizontally or vertically facing upwards.
- Compact
- Robust and reliable
- Simple design, easy installation

Technical description

Important notice:

The indicated pressure for the different categories of fluids (L1/L2/G1/G2) is under no condition a guarantee of use. Therefore, it is essential to validate the use of products under given operating conditions.

DN mm	PN	PFA bar	PS - bar				Cat.	References	Vvs-nr
			L1	L2	G1	G2			
40	10/16	16	10	10	10	10	I	149G3550	
50	10/16	16	10	10	10	10	I	149G3551	
65	10/16	16	10	10	10	10	I	149G3552	
80	10/16	16	10	10	10	10	I	149F021283	
100	10/16	16	10	10	10	10	I	149F021284	
125	10/16	16	10	10	0,5	10	I	149F021285	
150	10/16	16	10	10	0,5	10	I	149F021286	
200	10	10	10	10	0,5	10	I	149F021287	
250	10	10	10	10	0,5	10	I	149F021288	
300	10	10	10	10	0,5	10	I	149F021289	

- **Connection** : Between flanges PN see table.
- **Permissible operating pressure PFA - water**-(for supply, distribution and disposal of water) : see table
- **Maximum permissible pressure PS -other mediums** : see table

• **θ** Mini. -10 °C
Maxi. 110 °C

• **Mediums** : Clear liquids

• **Approvals** :  PED 97/23/CE 

- **International construction Standards:**
CE conformity Directive 97/23/CE
Flange drilling according to EN 1092 series 2

Overall dimensions

DN mm	A mm	D mm	E mm	Weight kg
40	22	94	16	0,800
50	32	109	16	1,000
65	42	129	16	1,500
80	54	144	16	1,750
100	71	162	16	2,100
125	95	194	16	2,700
150	114	220	19	4,400
200	164	275	28	7,000
250	199	331	32	15,100
300	240	381	38	22,100

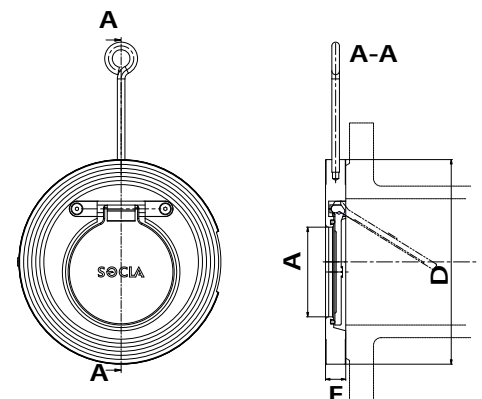

Technical data sheet Non return valve

Spare parts list and materials

Nb	Description	Materials	EURO	ANSI
1	CASING	Steel cataphoresis coated	GP240GH	
2	PLATE	Steel cataphoresis coated	GP240GH	
3	DISC HOLDING	Stainless steel	X5CrNi18-10	AISI 304
4	SCREW	Stainless steel	X5CrNi18-10	AISI 304
5	SEAL	EPDM		

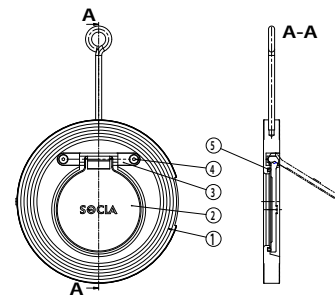

Working principle

DN	Opening pressure mm/WC	Kv	ζ
mm	near zero	m ³ /H	
40		17,3	13,76
50		49	4,19
65		93	3,25
80		141,8	3,3
100		218	3,34
125		412	2,29
150		514	3,06
200		1 069	2,23
250		1 569	2,54
300	2 459	2,14	

Directions for use :

- Solid line : Valve completely open
- Dotted line : opening stage of valve

