

KH3BWIIT

**3-DELIGE RVS KOGELKRAAN MET LASAANSLUITING BW
EN VALPES ELEKTRISCHE AANDRIJVING**

Huis constructie	3-delig met lasaansluiting BW
Aansluitingen	lasaansluiting BW
Drukklasse	PN63
Huismateriaal	RVS
Kogelmateriaal	RVS 316 ASTM A351 GR CF8M (1.4408)
Dichtingsmateriaal	RTFE
Doorlaat	Volle doorlaat
Bediening	Elektrische Aandrijving Type ER+



ITEM	PARTS	MATERIAL
1	body	ASTM A351-CF8M
2	cap	
3	ball	
4	bolt	AISI 304
5	nut	
6	spring washer	
7	ball seat	PTFE / RTFE
8	body seal	PTFE
9	thrust washer	
10	packing	
11	o-ring	VITON
12	stem	ASTM A276-316
13	gland ring	AISI 304
14	belleville washer	AISI 301
15	locking washer	AISI 304
16	locking device	
17	stem nut	
18	handle	STAINLESS STEEL
19	handle sleeve	PVC

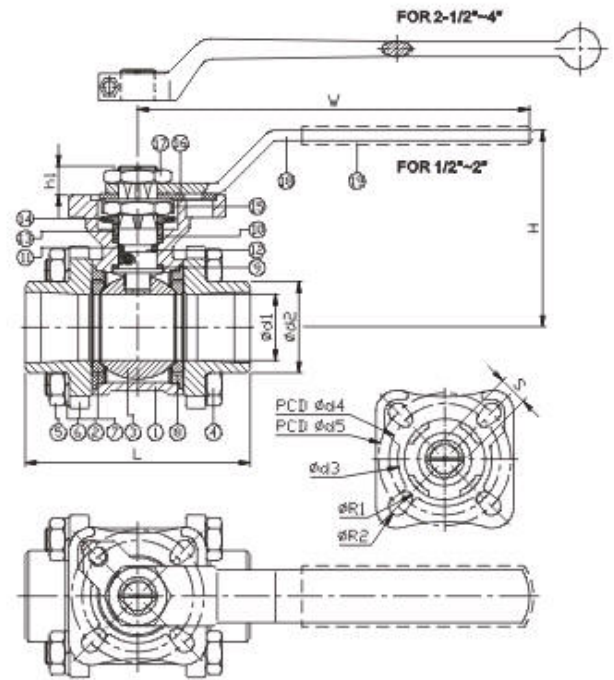

DN	d1	d2	L	H	W	S	h1	d3	d4	d5	R1	R2	Torque (N-m)
15	15	22.3	65	60	120	9	8.5	31	36	42	2.75	2.75	7.5
20	20	27.7	75	64									11
25	25	34.4	85	74									148
32	32	43.2	101	79	178	14	13.5	56	50	70	3.5	4.5	21
40	38	49.3	112	95									17
50	50	61.5	130	103									325
65	63	74.5	162	141	325	17	20.5	76	70	102	4.5	5.5	50
80	76	91	188	149.5									22
100	96	115.5	224	187.5									22
													97
													150

unit: mm

NPS	d1	d2	L	H	W	S	h1	d3	d4	d5	R1	R2	Torque (in-lb)
1/2"	0.59	0.88	2.56	2.36	4.72	0.35	0.33	1.22	1.42	1.65	0.11	0.11	66.4
3/4"	0.79	1.09	2.95	2.52									97.4
1"	0.98	1.35	3.35	2.91									5.83
1-1/4"	1.26	1.7	3.98	3.11	7.01	0.55	0.53	2.2	1.97	2.76	0.14	0.18	185.9
1-1/2"	1.5	1.94	4.41	3.74									239
2"	1.97	2.42	5.12	4.06									7.01
2-1/2"	2.48	2.93	6.38	5.55	12.8	0.67	0.81	2.99	2.76	4.02	0.18	0.22	752.3
3"	2.99	3.58	7.4	5.89									858.5
4"	3.78	4.55	8.82	7.38									12.8