

SITRANS FM (electromagnetic)

Flow sensors

SITRANS FMS500

Overview



The SITRANS FMS500 is a magnetic flow meter sensor suitable for volume flow measurement of liquids (conductive) and is the ideal product for applications in water abstraction, wastewater treatment, water distribution networks, and irrigation.

The rugged, fully welded design supports direct burial, constant flooding and to stand up a wide range of harsh chemicals found in water-based applications in many different industries.

Designed for highly accurate measurement in low-flow conditions, these meters can measure from very low velocities up to 10 m/s, giving it a very wide measurement range.

Combined with a flow meter transmitter it is a traditional externally powered electromagnetic flow meter system

Benefits

- Zero Up and Zero Down installation capabilities
- NBR rubber liner for all water and wastewater applications
- EPDM liner specifically for drinking water applications requiring special approvals
- Soft elastomer facing provides high abrasion resistance
- Increased low flow accuracy for water leak detection
- Rugged construction with no moving parts for maintenance-free operation over many years.
- Simple on-site upgrade to IP68 of a standard sensor allowing underground installation, permanent immersion or underwater installation
- Integrated grounding electrodes – no grounding rings required for many applications
- Short delivery time
- Built-in length according to ISO 20456 (up to DN 400 mm)
- SENSORPROM™ Technology provides an automatic upload of start-up settings and calibration data for easy commissioning
- Designed to allow in-situ verification for easy performance check
- In conformity with ISO 4064, OIML R49 and EN 14154

Application

The SITRANS FMS500 with its NBR or EPDM soft rubber lining is a flow meter sensor for all kinds of water applications such as ground water, potable water, cooling water, wastewater, sewage, or sludge applications.

Connected to the compatible transmitter SITRANS FMT020, either mounted remotely or as a compact unit, it forms the magnetic flow meter system SITRANS FM520 which can be used in almost all general-purpose water applications.

SITRANS FM520

Perfect match for a cost-effective solution for all water and wastewater applications. Measuring accuracy $\pm 0.4\%$ of flow rate, optional $\pm 0.2\%$ of flow rate available.

Selection and ordering data

Sensor SITRANS FMS500	Article No. 7ME653- • - • • • • • - 2 • A •	
Click on the Article No. for the online configuration in the PIA Life Cycle Portal.		
Transmitter variant		
No transmitter (sensor only)	0	
Transmitter SITRANS FMT020	2	
Diameter		
DN 15, 1/2 inch	1	V
DN 25, 1 inch	2	D
DN 40, 1 1/2 inch	2	R
DN 50, 2 inch	2	Y
DN 65, 2 1/2 inch	3	F
DN 80, 3 inch	3	M
DN 100, 4 inch	3	T
DN 125, 5 inch	4	B
DN 150, 6 inch	4	H
DN 200, 8 inch	4	P
DN 250, 10 inch	4	V
DN 300, 12 inch	5	B
DN 350, 14 inch	5	D
DN 400, 16 inch	5	H
DN 450, 18 inch	5	K
DN 500, 20 inch	5	R
DN 600, 24 inch	5	Y
DN 700, 28 inch	6	B
DN 750, 30 inch	6	D
DN 800, 32 inch	6	H
DN 900, 36 inch	6	K
DN 1000, 40 inch	6	R
DN 1050, 42 inch	6	Y
DN 1100, 44 inch	7	D
DN 1200, 48 inch	7	H
Process connection		
EN 1092-1 PN 10 flanges		B
EN 1092-1 PN 16 flanges		C
EN 1092-1 PN16 flanges, non-PED version		D
ANSI B16.5 Class 150 flanges		J
AWWA C-207 Class D flanges		M
AS 4087 PN 16 flanges		S
Process connection material		
Carbon steel ASTM A 105 with corrosion-resistant coating acc. to EN ISO 12944 grade C4		0
Carbon steel ASTM A 105 with corrosion-resistant coating acc. to EN ISO 12944 grade C5 (300 µm)		1
Liner material		
EPDM (soft rubber)		2
NBR (soft rubber)		3
Electrode material		
Hastelloy C276 / 2.4819		2
Transmitter mounting & enclosure type		
No transmitter (sensor only)		A
Compact design (integral mount), plastic enclosure		G
Remote design, plastic enclosure (wall-mounting unit and sensor terminal board included)		J
Power supply		
None (sensor only)		0
24 V DC		2
100 ... 240 V AC, 50/60 Hz		3

Selection and ordering data (continued)

Additional information	Order code
Please add "-Z" to Article No. and specify Order code(s) and plain text.	
Cable glands	
Without cable glands (blind plugs)	A00
M20x1.5 cable glands, material polyamide	A02
1/2 inch NPT cable glands, material polyamide	A05
Certificates	
Declaration of compliance with the order 2.1 (EN 10204)	C00
Inspection certificate 3.1 (EN 10204) - Material of pressure-containing and wetted parts	C12
Test report 2.2 (EN 10204)	C14
Inspection certificate 3.1(EN 10204) - Pressure test	C18
High accuracy calibration	
High accuracy factory calibration 0.2%, DN ≤ 200, ≤ 8 inch	D01
High accuracy factory calibration 0.2%, DN 250 ... 600, 10 ... 24 inch	D02
High accuracy factory calibration 0.2%, DN 700 ... 1200, 28 ... 48 inch	D03
5-point calibration	
5-point factory calibration, DN ≤ 200, ≤ 8 inch	D10
5-point factory calibration, DN 250 ... 600, 10 ... 24 inch	D11
5-point factory calibration, DN 700 ... 1200, 28 ... 48 inch	D12
10-point calibration	
10-point factory calibration, DN ≤ 200, ≤ 8 inch	D15
10-point factory calibration, DN 250 ... 600, 10 ... 24 inch	D16
10-point factory calibration, DN 700 ... 1200, 28 ... 48 inch	D17
Default matched-pair calibration	
Default matched-pair factory calibration, DN ≤ 200, ≤ 8 inch	D20
Default matched-pair factory calibration, DN 250 ... 600, 10 ... 24 inch	D21
Default matched-pair factory calibration, DN 700 ... 1200, 28 ... 48 inch	D22
5-point matched-pair calibration	
5-point, matched-pair factory calibration, DN ≤ 200, ≤ 8 inch	D25
5-point, matched-pair factory calibration, DN 250 ... 600, 10 ... 24 inch	D26
5-point, matched-pair factory calibration, DN 700 ... 1200, 28 ... 48 inch	D27
10-point matched-pair calibration	
10-point, matched-pair factory calibration, DN ≤ 200, ≤ 8 inch	D30
10-point, matched-pair factory calibration, DN 250 ... 600, 10 ... 24 inch	D31
10-point, matched-pair factory calibration, DN 700 ... 1200, 28 ... 48 inch	D32
Accredited ISO/IEC 17025 calibration	
ISO/IEC 17025 accredited, 5-point, matched-pair factory calibration, DN ≤ 200, ≤ 8 inch	D35
ISO/IEC 17025 accredited, 5-point, matched-pair factory calibration, DN 250 ... 600, 10 ... 24 inch	D36
ISO/IEC 17025 accredited, 5-point, matched-pair factory calibration, DN 700 ... 1200, 28 ... 48 inch	D37
General safety	
CSA General Purpose	E06

Additional information	Order code
Country of origin	
France	E90
Communication	
HART with 4 ... 20 mA output, active or passive	F01
Modbus RTU / RS485	F04
PROFINET	F07
EtherNet/IP	F09
Device options	
Sensor terminal board factory mounted	J00
Sensor cables factory mounted	J01
Factory preconfigured for transmitter mounting in compact design (integral mount)	J02
Type of protection (IP)	
IP68 (NEMA 6P) protection class for sensor in remote design, without potting (to 2 m depth, 10 days)	L50
IP68 (NEMA 6P) protection class for sensor in remote design, factory potted (to 10 m depth, continuously)	L51
Sensor cables	
Cable kit with coil and electrode cable, standard type (3 × 1.5 mm ²), PVC-jacket	
• 5 m (16 ft)	T00
• 10 m (33 ft)	T01
• 20 m (65 ft)	T03
• 30 m (98 ft)	T05
• 40 m (131 ft)	T06
• 50 m (164 ft)	T07
• 60 m (197 ft)	T08
• 100 m (328 ft)	T11
• 150 m (492 ft)	T14
• 200 m (656 ft)	T16
• 500 m (1640 ft)	T18
Cable kit with coil cable standard type (3 × 1.5 mm ²) and electrode cable special type (3 × 0.25 mm ²), PVC-jacket	
• 5 m (16 ft)	T50
• 10 m (33 ft)	T51
• 15 m (49 ft)	T52
• 20 m (65 ft)	T53
• 25 m (82 ft)	T54
• 30 m (98 ft)	T55
• 40 m (131 ft)	T56
• 50 m (164 ft)	T57
• 60 m (197 ft)	T58
• 100 m (328 ft)	T61
• 150 m (492 ft)	T64
• 200 m (656 ft)	T66
• 500 m (1640 ft)	T68
Device settings	
Measuring range: Upper range value (Q _{max}), unit	Y01
Current output damping	Y02
Current output signal range	Y03
Low flow cut off	Y04
Flow direction (Default setting: Positive)	Y05

Selection and ordering data (continued)

Additional information	Order code
Empty pipe detection (Default setting: On)	Y06
Mains frequency (Default setting: 50 Hz)	Y07
Operation language display (default setting English)	Y24
Device identification	
Location designation (TAG), device parameter and stainless-steel plate for transmitter (max. 32 characters)	Y11
Measuring point description, device parameter and stainless-steel plate for transmitter (max. 32 characters)	Y12
Location designation (TAG), device parameter and adhesive label for transmitter (max. 32 characters)	Y13
Measuring point description, device parameter and adhesive label for transmitter (max. 32 characters)	Y14
Location designation (TAG), device parameter and stainless-steel plate (max. 32 characters)	Y15
Measuring point description, device parameter and stainless-steel plate (max. 32 characters)	Y16
Location designation (TAG), device parameter and adhesive label (max. 32 characters)	Y18
Measuring point description, device parameter and adhesive label (max. 32 characters)	Y19

Additional information	Order code
Totalizer 1 settings	
Preset value	Y30
Unit	Y31
Direction	Y32
Failure mode	Y33
Decimal point	Y34
Totalizer 2 settings	
Preset value	Y35
Unit	Y36
Direction	Y37
Failure mode	Y38
Decimal point	Y39
Totalizer 3 settings	
Preset value	Y40
Unit	Y41
Direction	Y42
Failure mode	Y43
Decimal point	Y44
Pulse output settings	
Volume per pulse	Y50
Pulse width	Y51

Technical specifications

SITRANS FMS500 flowmeter sensor									
Product characteristic	For demanding applications in the water & wastewater industry								
Measurement of	Volume flow, flow velocity, electrical conductivity								
Nominal diameter	<ul style="list-style-type: none"> Coned sensor (octagon liner): DN 15 ... 40 (½" ... 1½") Coned sensor: DN 50 ... 300 (2" ... 12") Full bore sensor: DN 350 ... 1200 (14" ... 48") 								
Mode of operation	Electromagnetic induction								
Measuring principle	Liquids with an electrical conductivity $\geq 5 \mu\text{S/cm}$.								
Medium conductivity									
Excitation frequency (mains supply: 50 Hz / 60 Hz)	<ul style="list-style-type: none"> DN 15 ... 65 (1/2" ... 2 1/2"): 12.5 Hz / 15 Hz DN 80 ... 150 (3" ... 6"): 6.25 Hz / 7.5 Hz DN 200 ... 300 (8" ... 12"): 3.125 Hz / 3.75 Hz DN 350 ... 1200 (14" ... 48"): 1.5625 Hz / 1.875 Hz 								
Process connection									
Flanges ¹⁾									
<ul style="list-style-type: none"> EN 1092-1 ANSI B16.5 AWWA C-207 AS/NZS 4087 JIS B 2220:2004 	PN 10 (145 psi) Flat face DN 200 ... 300 (8" ... 12") PN 10 (145 psi) Raised face DN 350 ... 1200 (14" ... 48") PN 16 (232 psi) Flat face DN 50 ... 300 (2" ... 12") PN 16 (232 psi) Raised face DN 350 ... 1200 (14" ... 48") PN 40 (580 psi) Flat face DN 15 ... 40 (½" ... 1½") Class 150 Flat face ½" ... 12" Class 150 Raised face 14" ... 24" Class D Flat face 28 ... 48" PN 16 (232 psi) Flat Face DN 50 ... 300 (2" ... 12") PN 16 (232 psi) Raised face DN 350 ... 1200 (14" ... 48") 10K DN 15 ... 600 (1" ... 24")								
Rated operating conditions									
Ambient temperature									
<ul style="list-style-type: none"> Sensor Compact with transmitter 	-20 ... +70 °C (-40 ... +158 °F) -20 ... +65 °C (-40 ... +149 °F)								
Operating pressure (abs) (maximum operating pressure depending on flange type)	DN 15 ... 40 (1/2" ... 1 1/2"): 0.01 ... 40 bar (0.15 ... 580 psi) DN 50 ... 300 (2" ... 12"): 0.03 ... 20 bar (0.44 ... 290 psi) DN 350 ... 1200 (14" ... 48"): 0.01 ... 16 bar (0.15 ... 232 psi)								
Protection class									
<ul style="list-style-type: none"> Standard Optional 	IP66/67, NEMA 4X/6 IP68 and NEMA 6P (2m, 10 days) for sensor in remote design IP68 and NEMA 6P (10m, continuously) for sensor in remote design								
Mechanical load (vibration)									
<ul style="list-style-type: none"> Integral mount / compact version Remote version 	Vibration, sinusoidal according to IEC 60068-2-6 <ul style="list-style-type: none"> 2 ... 4 Hz, 3.5 mm peak 8.4 ... 500 Hz, 1 g peak Vibration broad-band random, according to IEC 60068-2-64 <ul style="list-style-type: none"> 10 ... 200 Hz, 0.003 g²/Hz 200 ... 500 Hz, 0.001 g²/Hz Total: 1.54 g rms Vibration, sinusoidal according to IEC 60068-2-6 <table border="1"> <thead> <tr> <th>Sensor</th> <th>Transmitter</th> </tr> </thead> <tbody> <tr> <td> <ul style="list-style-type: none"> 2 ... 8.4 Hz, 7.5 mm peak 8.4 ... 500 Hz, 2 g peak </td> <td> <ul style="list-style-type: none"> 2 ... 8.4 Hz, 1.5 mm peak 8.4 ... 500 Hz, 0.7 g peak </td> </tr> </tbody> </table> Vibration broad-band random, according to IEC 60068-2-64 <table border="1"> <thead> <tr> <th>Sensor</th> <th>Transmitter</th> </tr> </thead> <tbody> <tr> <td> <ul style="list-style-type: none"> 10 ... 200 Hz, 0.01 g²/Hz 200 ... 500 Hz, 0.003 g²/Hz Total: 1.54 g rms </td> <td> <ul style="list-style-type: none"> 10 ... 200 Hz, 0.003 g²/Hz 200 ... 500 Hz, 0.001 g²/Hz Total: 1.54 g rms </td> </tr> </tbody> </table>	Sensor	Transmitter	<ul style="list-style-type: none"> 2 ... 8.4 Hz, 7.5 mm peak 8.4 ... 500 Hz, 2 g peak 	<ul style="list-style-type: none"> 2 ... 8.4 Hz, 1.5 mm peak 8.4 ... 500 Hz, 0.7 g peak 	Sensor	Transmitter	<ul style="list-style-type: none"> 10 ... 200 Hz, 0.01 g²/Hz 200 ... 500 Hz, 0.003 g²/Hz Total: 1.54 g rms 	<ul style="list-style-type: none"> 10 ... 200 Hz, 0.003 g²/Hz 200 ... 500 Hz, 0.001 g²/Hz Total: 1.54 g rms
Sensor	Transmitter								
<ul style="list-style-type: none"> 2 ... 8.4 Hz, 7.5 mm peak 8.4 ... 500 Hz, 2 g peak 	<ul style="list-style-type: none"> 2 ... 8.4 Hz, 1.5 mm peak 8.4 ... 500 Hz, 0.7 g peak 								
Sensor	Transmitter								
<ul style="list-style-type: none"> 10 ... 200 Hz, 0.01 g²/Hz 200 ... 500 Hz, 0.003 g²/Hz Total: 1.54 g rms 	<ul style="list-style-type: none"> 10 ... 200 Hz, 0.003 g²/Hz 200 ... 500 Hz, 0.001 g²/Hz Total: 1.54 g rms 								
Process temperature									

Technical specifications (continued)

SITRANS FMS500 flowmeter sensor	
• NBR liner	-10 ... +70 °C (14 ... 158 °F)
• EPDM liner	-10 ... +70 °C (14 ... 158 °F)
Pressure drop	DN 15 and 25 (½" and 1"): Max. 20 mbar (0.29 psi) at 1 m/s (3 ft/s) DN 40 ... 300 (1½" ... 12"): Max. 25 mbar (0.36 psi) at 3 m/s (10 ft/s) DN 350 ... 1200 (14" ... 48"): Insignificant
Test pressure	1.5 × PN (where applicable)
Design	
Dimensions	See dimensional drawings
Weight	See dimensional drawings
Material	
• Housing and flanges	Carbon steel ASTM A 105 with corrosion resistant coating of class C4 or C5 (durability up to 15 years) EN ISO 12944
• Measuring electrode	Hastelloy C276 / 2.4819
• Grounding electrode	Hastelloy C276 / 2.4819
• Measuring pipe ²⁾	Stainless steel AISI 304 / 1.4301
• Terminal box	Polycarbonate
Cable entries	4 x metric thread (size M20 x 1.5)
Pressure equipment	Conforming with 97/23 EC
Electromagnetic compatibility	Conforming with 2004/108/EC
Calibration	
Standard	Zero-point, 2 × 25 % and 2 × 90 %
Optional	<ul style="list-style-type: none"> • 5-point calibration: 20 %, 40 %, 60 %, 80 %, 100 % of factory Qmax • 10-point calibration: ascending and descending at 20 %, 40 %, 60 %, 80 %, 100 % of factory Qmax • Matched pair calibration: default, 5-point or 10-point • ISO/IEC 17025 accredited, 5-point, matched-pair calibration
Certificates and approvals	
General purpose	CE (LVD, PED, EMC, RoHS), UKCA
Drinking water	<ul style="list-style-type: none"> • WRAS (WRc, BS 6920 material approval for cold water, GB) • NSF/ANSI Standard 61 (Cold water, US) • ACS listed (France) • DVGW W270 (Germany) • Belgaqua (Belgium) • AS/NZS 4020 (Australia/New Zealand) • GB/T 5750 (China)
Others	<ul style="list-style-type: none"> • Environmental Product Declaration (EPD) • EAC (Kazakhstan)

¹⁾ DN 750, DN 1050 and DN 1100 (30", 42" and 44") not available with EN 1092-1 (PN 10 and PN 16) and AS 4087 flanges

²⁾ DN > 300 (12")

Dimensional drawings

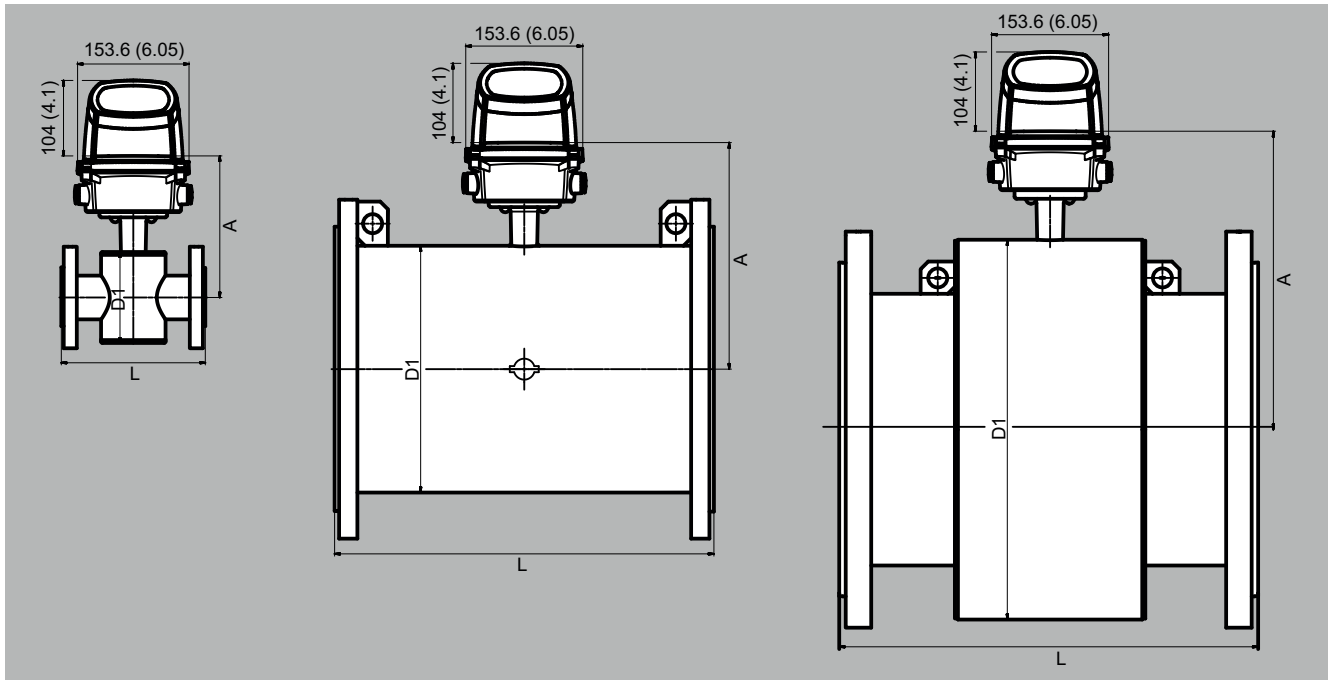

SITRANS FMS500 Sensor: version 7ME6530 DN 15 ... 40 (½" ... 1½") (left), version 7ME6530 DN 50 ... 300 (2" ... 12") (middle) and version 7ME6530 DN 350 ... 1200 (14" ... 48") (right)

Sensor SITRANS FMS500 (7ME653)									
Nominal diameter		A		D1		L1)		Weight ²⁾	
[mm]	[inch]	[mm]	[inch]	[mm]	[inch]	[mm]	[inch]	[kg]	[lbs]
15	½	170	6.7	77	3.0	200	7.9	5	11
25	1	180	7.1	96	3.8	200	7.9	6	13
40	1½	195	7.7	127	5.0	200	7.9	9	20
50	2	181	7.1	76	3.0	200	7.9	10	22
65	2½	187	7.4	89	3.5	200	7.9	12	26
80	3	193	7.6	102	4.0	200	7.9	13	29
100	4	200	7.9	114	4.5	250	9.8	17	37
125	5	210	8.3	140	5.5	250	9.8	20	44
150	6	225	8.9	168	6.6	300	11.8	27	60
200	8	250	9.8	219	8.6	350	13.8	39	86
250	10	277	10.9	273	10.8	450	17.7	56	123
300	12	303	11.9	324	12.8	500	19.7	72	159
350	14	375	14.8	451	17.8	550	21.7	115	254
400	16	400	15.7	502	19.8	600	23.6	143	315
450	18	431	17.0	563	22.2	600	23.6	177	390
500	20	456	18.0	614	24.2	600	23.6	222	489
600	24	507	20.0	715	28.2	600	23.6	321	708
700	28	557	21.9	816	32.1	700	27.6	331	730
750	30	584	23.0	869	34.2	750	29.5	-	-
800	32	609	24.0	927	36.5	800	31.5	386	851
900	36	656	25.8	1032	40.6	900	35.4	482	1063
1000	40	707	27.8	1136	44.7	1000	39.4	672	1482
1050	42	707	27.8	1136	44.7	1000	39.4	-	-
1100	44	758	29.8	1238	48.7	1100	43.3	-	-
1200	48	813	32.0	1348	53.1	1200	47.2	1116	2460

¹⁾ Tolerances on built-in length: DN 15 ... 200 (½" ... 8"): +0/-3 mm (+0/-0.12"), DN 250 ... 400 (10" ... 16"): +0/-5 mm (+0/-0.20"), DN 450 ... 600 (18" ... 24"): +5/-5 mm (+0.20/-0.20"), DN 700 ... 1200 (28" ... 48"): +10/-10 mm (+0.39/-0.39")

²⁾ Weights in kg/lbs are for PN 40 DN ≤40, PN 16 DN >40 without transmitter. With transmitter FMT020 installed, weight is increased by approximately 1.0 kg (2.2 lb).