

# KA3BWIIT

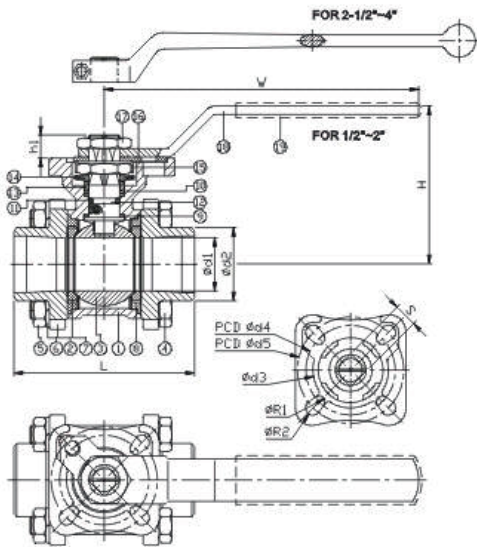

## FEATURES

1. Full port, 1/2"~4" (DN15~DN100)
2. W. P.: 1000 WOG(PN63)
3. W. T.: -20°C ~200°C (-4℉~392℉)
4. Investment casting
5. Blow-out proof stem
6. Live-loading design
7. Locking device
8. ISO 5211 direct mounting pad
9. Length conform to DIN 3202/4-M3-2012ND-M3 (option)
10. ISO 15848 fugitive emission approved (option)
11. Automation accessories (option)
12. Butt weld ends conform to ANSI B16.25 & DIN 3239 part1



ITEM	PARTS	MATERIAL
1	BODY	ASTM A351-CF8M
2	CAP	
3	BALL	ANSI 304
4	BOLT	
5	NUT	
6	SPRING WASHER	PTFE/RTFE
7	BALL SEAT	
8	BODY SEAL	PTFE
9	THRUST WASHER	
10	PACKING	VITON
11	O-RING	
12	STEM	ASTM A276-316
13	GLAND RING	AISI 304
14	BELLEVILLE WASHER	AISI 301
15	LOCKING WASHER	AISI 304
16	LOCKING DEVICE	
17	STEM NUT	STAINLESS STEEL
18	HANDLE	
19	HANDLE SLEEVE	PVC

# KA3BWIIT

DN	d1	d2	L	H	W	S	h1	d3	d4	d5	R1	R2	Torque (N-M)
15	15	22.3	65	60	120	9	8.5	31	36	42	2.75	2.75	7.5
20	20	27.7	75	64									11
25	25	34.4	85	74	148	11	11	35.5	42	50	2.75	3.5	14
32	32	43.2	101	79									14
40	38	49.3	112	95	178	14	13.5	56	50	70	3.5	4.5	27
50	50	61.5	130	103									17
65	63	74.5	162	141	325	17	20.5	76	70	102	4.5	5.5	85
80	76	91	188	149.5									22
100	96	115.5	224	187.5									22.5

unit:mm

NPS	d1	d2	L	H	W	S	h1	d3	d4	d5	R1	R2	Torque (in-lb)
1/2"	0.59	0.88	2.56	2.36	4.72	0.35	0.33	1.22	1.42	1.65	0.11	0.11	66.4
3/4"	0.79	1.09	2.95	2.52									0.43
1"	0.98	1.35	3.35	2.91	5.83	0.43	0.43	1.4	1.65	1.97	0.11	0.14	123.9
1-1/4"	1.26	1.7	3.98	3.11									0.55
1-1/2"	1.5	1.94	4.41	3.74	7.01	0.55	0.53	2.2	1.97	2.76	0.14	0.18	239
2"	1.97	2.42	5.12	4.06									0.67
2-1/2"	2.48	2.93	6.38	5.55	12.8	0.67	0.81	2.99	2.76	4.02	0.18	0.22	752.3
3"	2.99	3.58	7.4	5.89									0.87
4"	3.78	4.55	8.82	7.38									0.89

unit:in