

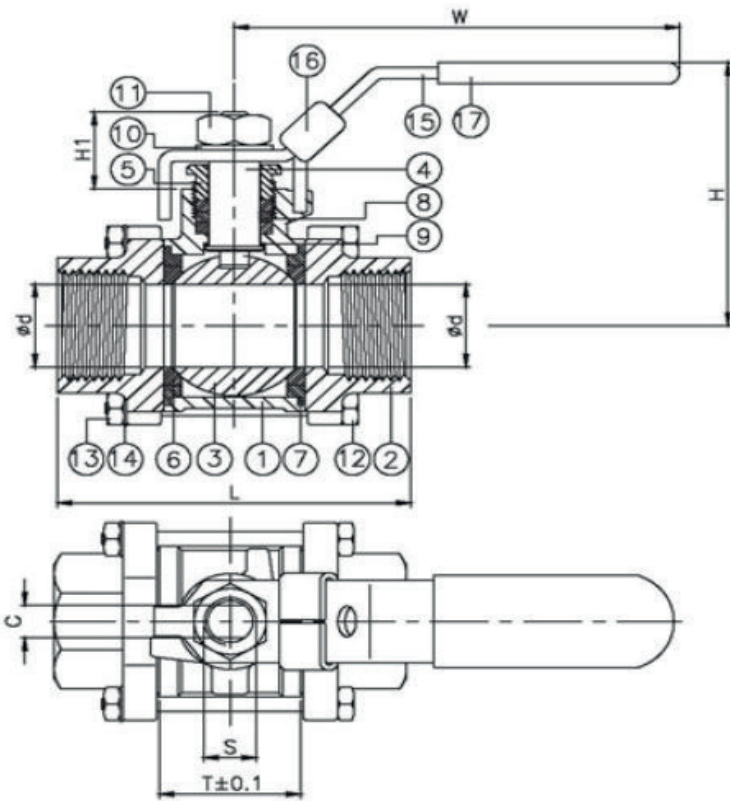

FEATURES

- 1.Full port, 1/4"~4" (DN8~DN100)
- 2.W. P.: 1000 WOG(PN63)
- 3.W. T.: -20°C ~200°C (-4°F~392°F)
- 4.Investment casting
- 5.Blow-out proof stem
- 6.Locking device
- 7.TA-Luft approved (option)
- 8.Length conform to DIN 3202/4-M3-2013N-M3 (option)
- 9.Thread type: ASME B1.20.1 (NPT) DIN2999 & BS21 ISO7/1 & EN10226



ITEM	PARTS	MATERIAL	
1	BODY	ASTM A351- CF8M	ASTM A216- WCB
2	CAP		
3	BALL	ASTM A351-CF8M	
4	STEM	ASTM A276-316	
5	GLAND NUT	AISI 304	
6	SEAT	PTFE / RTFE	
7	SEAL	PTFE	
8	PACKING		
9	THRUST WASHER		
10	SPRING WASHER	AISI 304	
11	STEM NUT		
12	BOLT		
13	NUT		
14	SPRING WASHER	STAINLESS STEEL	
15	HANDLE		
16	LOCKING DEVICE		
17	HANDLE SLEEVE	PVC	

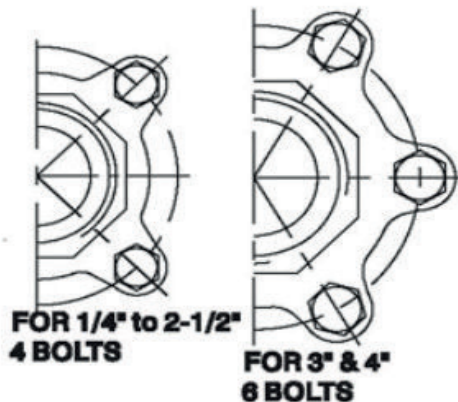

DN	d1	L	H	H1	W	T	C	S	Torque (N-M)	Weight (kg)
8	11.6	65	58.5	18	100	21.6	5	3/8"~24UNF	3.5	0.4
10	12.5	65	58.5	18	100	21.6	5	3/8"~24UNF	4	0.4
15	15	65	62	18.5	100	24	5	3/8"~24UNF	5.5	0.5
20	20	75	62	22.5	125	29.7	6.5	7/16"~20UNF	7.5	0.7
25	25	85	77	25	149	34.4	7.9	7/16"~20UNF	11	1
32	32	101	82	26	149	42.8	7.9	7/16"~20UNF	15	1.6
40	38	112	100	30	190	51.1	10	1/2"~20UNF	20	2.5
50	50	130	108	30	190	63.4	10	1/2"~20UNF	40	3.5
65	63	162	137	40	250	81.2	12	3/4"~10UNC	60	6.7
80	76	188	145	40	250	95.6	12	3/4"~10UNC	85	9.5
100	96	224	179	54	323	127.1	16	1"~8UNC	150	19.1

unit:mm

NPS	d1	L	H	H1	W	T	C	S	Torque (in-lb)	Weight (lb)
1/4"	0.46	2.56	2.3	0.71	3.94	0.85	0.2	3/8"~24UNF	31	0.8
3/8"	0.49	2.56	2.3	0.71	3.94	0.85	0.2	3/8"~24UNF	35.4	0.8
1/2"	0.59	2.56	2.44	0.73	3.94	0.94	0.2	3/8"~24UNF	48.7	1.1
3/4"	0.79	2.95	2.44	0.89	4.92	1.17	0.26	7/16"~20UNF	66.4	1.5
1"	0.98	3.35	3.03	0.98	5.87	1.35	0.31	7/16"~20UNF	97.4	2.2
1-1/4"	1.26	3.98	3.23	1.02	5.87	1.69	0.31	7/16"~20UNF	132.8	3.5
1-1/2"	1.5	4.41	3.94	1.18	7.48	2.01	0.39	1/2"~20UNF	177	5.5
2"	1.97	5.12	4.25	1.18	7.48	2.5	0.39	1/2"~20UNF	354	7.7
2-1/2"	2.48	6.38	5.39	1.57	9.84	3.2	0.47	3/4"~10UNC	531	14.8
3"	2.99	7.4	5.71	1.57	9.84	3.76	0.47	3/4"~10UNC	752.3	20.9
4"	3.78	8.82	7.05	2.13	12.72	5	0.63	1"~8UNC	1327.6	42.1

unit:in