

**BALL VALVE ISO
FULL BORE, DN25-DN200**

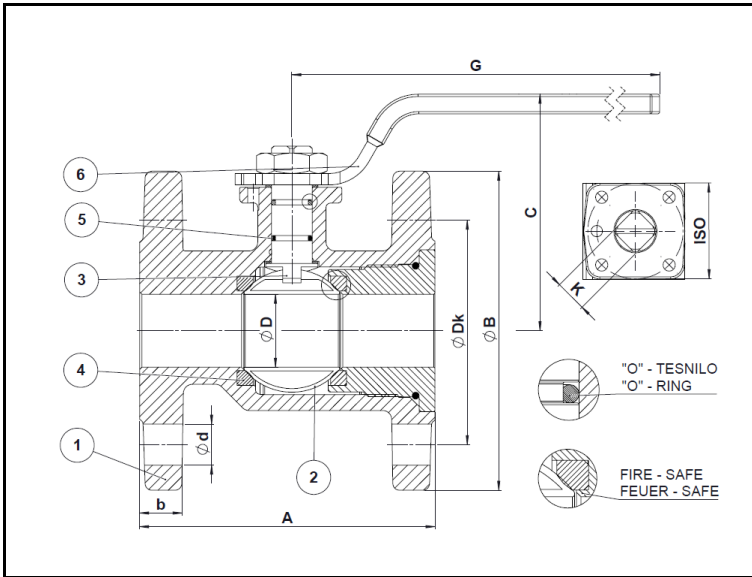

DN25-DN50

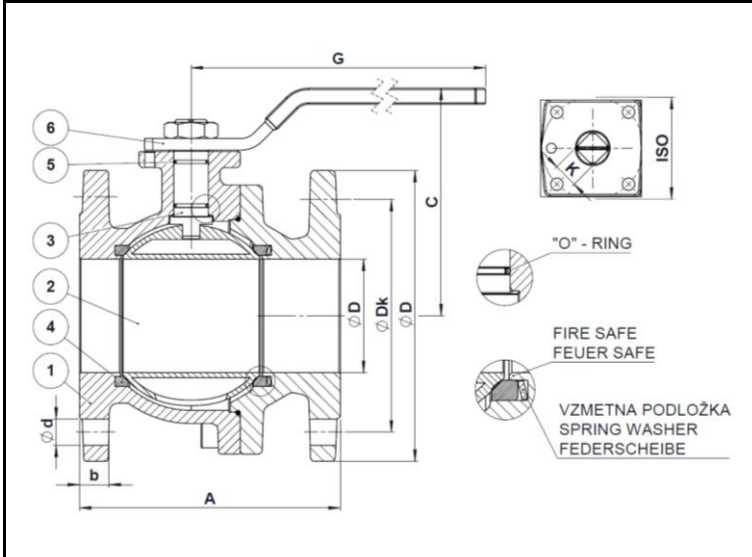
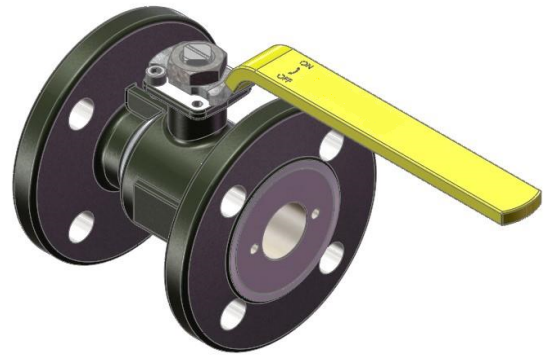

DN65-DN150

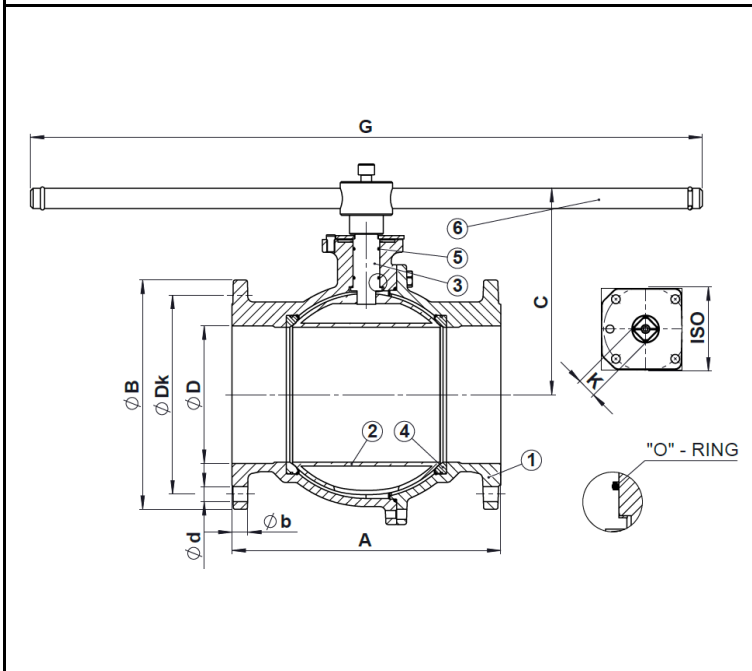

DN200



Materials

1	Body	Ductile Iron – EN-GJS-400-15 (GGG40)
2	Ball	Stainless Steel – X5CrNi18-10 (A304)
3	Stem	Stainless Steel – X30Cr13 (A420)
4	Seats	PTFE
5	O-Ring	Viton
6	Handle	Carbon steel (Galvanized) – S235JR (St 37-2)

Working temperature -20 °C/+60 °C

PN16

DN ... PN16 DP VX PX - ISO

Art. nr.	DN	A	ØB	C	ØD	G	b	ØDk	Ød	Nr.	Top flange ISO	Shaft K x h	Weight (kg)
KLGI1FD1640IT025	25	125	115	76	25	153	18	85	14	4	F03	□11 x 13,5	3,85
KLGI1FD1640IT032	32	130	140	92	31	237	18	100	18	4	F04	□14 x 18	5,60
KLGI1FD1640IT040	40	140	150	97	39	276	18	110	18	4	F05	□14 x 18	6,75
KLGI1FD1640IT050	50	150	165	105	49	276	20	125	18	4	F05	□14 x 18	8,90
KLGI1FD1640IT065	65	170	185	124	63	340	18	145	18	4	F07	□17 x 23	14,00
KLGI1FD1640IT080	80	180	200	133	76	340	20	160	18	8	F07	□17 x 23	17,65
KLGI1FD1640IT100	100	190	220	153	100	340	20	180	18	8	F07	□17 x 23	21,80
KLGI1FD1640IT125	125	200	250	183	125	541	22	210	18	8	F10	□22 x 27	29,70
	125	325*	250	183	125	541	22	210	18	8	F10	□22 x 27	34,60
KLGI1FD1640IT150	150	210	285	203	142	541	22	240	22	8	F10	□22 x 27	38,55
	150	350*	285	203	142	541	22	240	22	8	F10	□22 x 27	45,70
KLGI1FD1640IT200	200	400*	340	316	200	1000	24	295	22	12	F12	□27 x 31	85,65

Notes

DN25 and DN32 are with inox full ball.

Face to face dimensions conform to DIN3202 F4.

*Face to face dimensions conform to DIN3202 F5.



Ball valves for oxygen available upon request.