

SITRANS LR500 series

Overview



SITRANS LR500 series are 80 GHz radar level transmitters for continuous monitoring of liquids, slurries, and solids in storage and process vessels including high temperature and pressure, to a range of 120 m (393 ft).

Benefits

- Continuous level measurement up to 120 m (393 ft)
- Easy installation and simple startup
- Programming using 4-button HMI, mobile IQ app using Bluetooth, or SIMATIC PDM
- IQ Guard for health monitoring, NE107 diagnostic messaging and quality verification report
- Communication using HART 7
- Graphical HMI with echo profile display and backlight
- Near Range Suppression for automatic detection and suppression of material build up noise
- Process Intelligence signal processing
- 1 mm accuracy in accordance with IEC 60770-1
- Suitable for API 2350
- Auto False Echo Suppression for fixed obstruction avoidance
- Low power consumption with EPD (environmental product declaration)
- Optional SLOD (second line of defense) for toxic material safety
- 100 000 points of data logging memory for process control analysis and optimization

Application

SITRANS LR500 series radar level transmitters include a graphical local user interface that improves setup and operation by including an intuitive Quick Start Wizard, and echo profile displays for diagnostic support.

The 80 GHz frequency creates a narrow, focused beam allowing for smaller antenna and decreasing sensitivity to obstructions.

SITRANS LR500 series radar level transmitters measure superbly on low dielectric media with high accuracy and repeatability. A very fast measurement response is ideal for process control applications.

- Key Applications: SITRANS LR500 Radar level transmitters are available with four antenna types for level measurement of liquid, slurry, and solid materials:
  - Threaded lens antenna
  - Flanged encapsulated antenna
  - Polymeric horn antenna
  - Flanged lens antenna

Selection and ordering data

	Article No.
<b>SITRANS LR500 Series Continuous, non-contact, 120 m (394 ft) range, for liquids, slurries, and solids in storage and process vessels, including high temperature and pressure.</b>	
<b>Antenna versions</b>	
Threaded lens antenna	7ML751-.....
Flanged encapsulated antenna	7ML753-.....
Polymeric horn antenna	7ML755-.....
Flanged lens antenna	7ML758-.....

## Technical specifications

SITRANS LR500 Series	
<b>Mode of operation</b>	
Measuring principle	Radar level measurement
Frequency	W band (80 GHz nominal)
Minimum detectable distance	0 mm from end of the antenna (antenna dependent, reference conditions)
Maximum measuring range	120 m (394 ft), antenna dependent
<b>Output</b>	
HART	Version 7
• Analog output	4 ... 20 mA
• Fail-safe	Programmable as high, low, or hold (loss of echo)
• Update time	Up to 3 measurements per second
<b>Performance (according to reference conditions IEC60770-1)</b>	
Maximum measured error	1 mm (0.039 inch)
Influence of ambient temperature	Less than 3 mm/10 K and maximum ±5 mm over full range from -40 ... +80 °C (-40 ... +176 °F) API 3.1B Inventory
<b>Rated operating conditions</b>	
Installation conditions	
• Location	Indoor/outdoor
Ambient conditions (enclosure)	
• Ambient temperature	-40 ... +80 °C (-40 ... +176 °F)
• Storage temperature	-40 ... +80 °C (-40 ... +176 °F)
• Installation category	I
• Pollution degree	4
<b>Medium conditions</b>	
Dielectric constant $\epsilon_r$	> 1.6, antenna and application dependent
Process temperature	-196 ... 250 °C (-321 ... 482 °F), antenna and seal dependent
Process pressure	Up to 40 bar g (580 psi g), process connection and temperature dependent.
<b>Design</b>	
Weight	Range from 2 ... 20 kg (4.4 ... 44.1 lb), version dependent
Enclosure	
• Material	Aluminum, polyester powder-coated, C5 corrosion equivalent
• Cable inlet	2 x M20 x 1.5 or 2 x ½" NPT
Degree of protection	Type 4X, Type 6, IP66, IP68
Display (local)	Optional graphical HMI with NE107 diagnostic data, echo profile display and backlight
Trend Logging	100 000 points, up to 8 variables including level, distance, space, volume, signal strength, confidence, temperature
Limit Monitoring	Min/Max of 3 variables with count function
Terminal voltage	Available from HMI or EDD
Asset management	Diagnostic logbook, parameter change logbook
<b>Power supply</b>	
4 ... 20 mA/HART	Nominal 24 V DC (max. 30 V DC) with max. 800 Ω
<b>Certificates and approvals</b>	
Ordinary locations	FM, cCSA <sub>US</sub> , CE
Radio	CE, FCC, IC, RCM

## Technical specifications (continued)

Hazardous areas	ATEX, IECEx, UKCA Intrinsically Safe Ex ia IIC T6 Ga ATEX, IECEx, UKCA Intrinsically Safe Ex ia IIIC Txx°C Da ATEX, IECEx, UKCA Dust Ignition proof Ex ta IIIC Txx°C Da ATEX, IECEx, CSA, FM, UKEX, NEPSI, PESO, INMETRO EX II 1GD EX ia IIC T6 ... T4 Ga Ex ia IIIC T <sub>200</sub> 95 °C Da Ta Ex ta IIIC T <sub>200</sub> 137 °C Da CSA/FM Intrinsically Safe Ex ia Class I, II, III, Div 1, Groups A, B, C, D, E, F, G T6 CSA/FM Non-Incendive Class I, Div. 2, Groups A, B, C, D T6
Materials	3.1 of EN 10204, NACE MR 0175 and MR 0103, 2.2 of EN 10204, PMI CRN, PED
Pressure	Canadian Registration Number (CRN) Note: CRN is not applicable for process temperatures below -40 °C (-40 °F).
• British Columbia	0F7424.1
• Alberta	0F22399.2
• Saskatchewan	0F7424.13
• Manitoba	0F7424.14
• Ontario	0F7424.15
• Quebec	0F07424.16
• Atlantic Canada and Territories	0F1384.9870YNT
Materials	3.1 of EN 10204, NACE MR 0175 and MR 0103, 2.2 of EN 10204, PMI
<b>Programming</b>	
PC	SIMATIC PDM
Display (local)	Optional graphical HMI with NE107 diagnostic data, echo profile display and backlight
SITRANS mobile IQ app	Optional AW050 Bluetooth module, for non-hazardous applications only

## Options

Sun shield cover

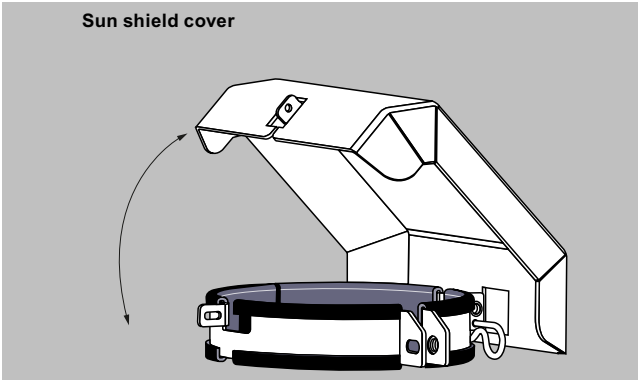

SITRANS LR500 series sunshield

SITRANS AW050 Bluetooth adapter

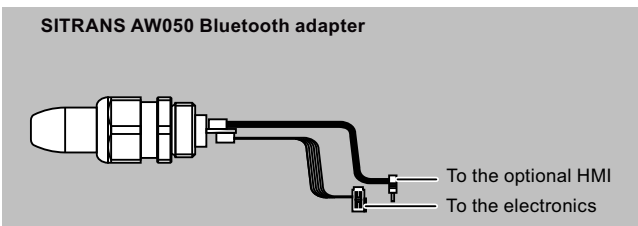

SITRANS AW050 Bluetooth adapter

## Dimensional drawings

### SITRANS LR500 series antenna versions

Thread with integrated antenna system

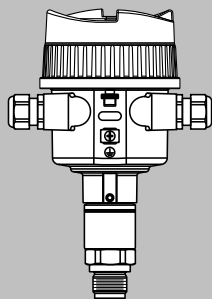

Plastic horn antenna

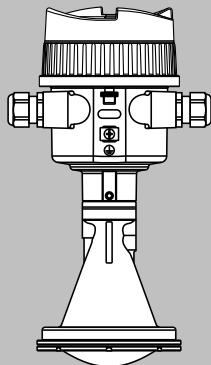

Flange with encapsulated antenna system

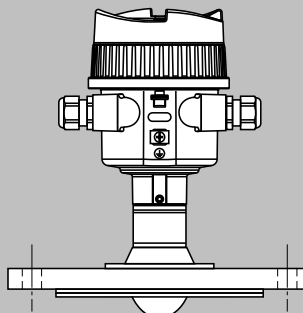

Flange with lens antenna

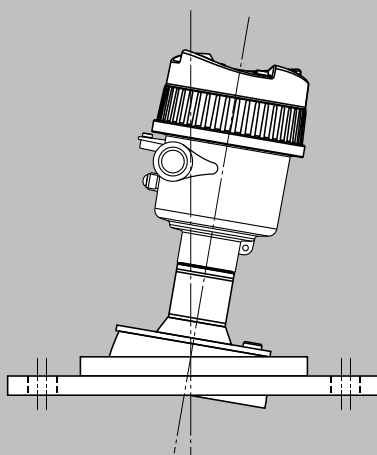

SITRANS LR500 Series antenna versions

## Overview



SITRANS LR530 flange encapsulated antenna provides continuous monitoring of liquids and slurries to a range of 120 m (394 ft). The PTFE lens and integrated gasket is easy to clean and ideal for highly corrosive media.

## Configuration

### Installation of SITRANS LR530

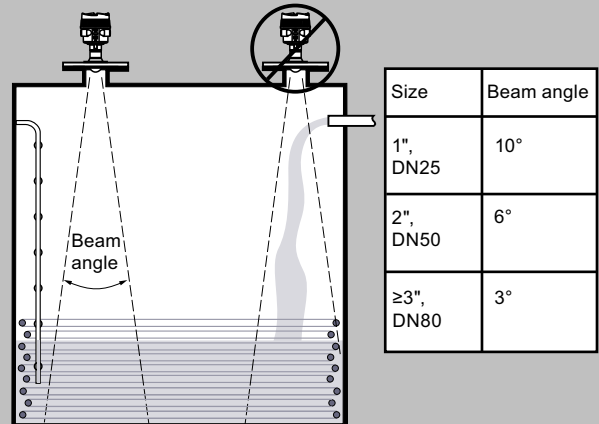

### SITRANS LR530 nozzle mounting restrictions

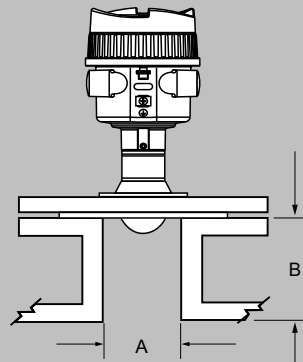

Nozzle diameter "A"		Nozzle height "B"	
50 mm	2"	≤200 mm	≤ 7.9"
80 mm	3"	≤400 mm	≤ 15.8"
100 mm	4"	≤500 mm	≤ 19.7"
150 mm	6"	≤800 mm	≤ 31.5"

SITRANS LR530 Nozzle installation

## Selection and ordering data

		Article No.									
<b>SITRANS LR530 Flanged encapsulated PTFE Continuous, non-contact, 120 m (394 ft) range, for liquids and slurries.</b>		7	M	L	7	5	3	0	-	0	0
Click on the Article No. for the online configuration in the PIA Life Cycle Portal.											
<b>Communications</b>											
4 ... 20 mA, HART		0									
<b>Sealing material of the antenna/process connection</b>											
PTFE / PTFE / -60 ... +150 °C (-76 ... +302 °F)		0									
PTFE / PTFE / -196 ... +200 °C (-321 ... +392 °F)		1									
<b>Process connection type and material</b>											
Flange DN25 PN6, raised face, Form B1, EN1092-1, DIN2501 / 316/316L				K		A					
Flange DN50 PN6, raised face, Form B1, EN1092-1, DIN2501 / 316/316L				K		B					
Flange DN80 PN6, raised face, Form B1, EN1092-1, DIN2501 / 316/316L				K		C					
Flange DN100 PN16, raised face, Form B1, EN1092-1, DIN2501 / 316/316L				K		D					
Flange DN150 PN16, raised face, Form B1, EN1092-1, DIN2501 / 316/316L				K		E					
Flange DN200 PN16, raised face, Form B1, EN1092-1, DIN2501 / 316/316L				K		F					
Flange DN25 PN40, raised face, Form B1, EN1092-1, DIN2501 / 316/316L				L		A					
Flange DN50 PN40, raised face, Form B1, EN1092-1, DIN2501 / 316/316L				L		B					
Flange DN80 PN40, raised face, Form B1, EN1092-1, DIN2501 / 316/316L				L		C					
Flange DN100 PN40, raised face, Form B1, EN1092-1, DIN2501 / 316/316L				L		D					
Flange DN150 PN40, raised face, Form B1, EN1092-1, DIN2501 / 316/316L				L		E					
Flange 1" 150 lb RF, ASME B16.5 / 316/316L				M		A					
Flange 2" 150 lb RF, ASME B16.5 / 316/316L				M		B					
Flange 3" 150 lb RF, ASME B16.5 / 316/316L				M		C					
Flange 4" 150 lb RF, ASME B16.5 / 316/316L				M		D					
Flange 6" 150 lb RF, ASME B16.5 / 316/316L				M		E					
Flange 8" 150 lb RF, ASME B16.5 / 316/316L				M		F					
Flange 1" 300 lb RF, ASME B16.5 / 316/316L				N		A					
Flange 2" 300 lb RF, ASME B16.5 / 316/316L				N		B					
Flange 3" 300 lb RF, ASME B16.5 / 316/316L				N		C					
Flange 4" 300 lb RF, ASME B16.5 / 316/316L				N		D					
Flange 6" 300 lb RF, ASME B16.5 / 316/316L				N		E					
Flange 8" 300 lb RF, ASME B16.5 / 316/316L				N		F					
Flange DN25 5K RF, JIS / 316/316L				V		A					
Flange DN50 10K RF, JIS / 316/316L				V		B					
Flange DN80 10K RF, JIS / 316/316L				V		C					
Flange DN100 10K RF, JIS / 316/316L				V		D					
Flange DN150 10K RF, JIS / 316/316L				V		E					
<b>Second line of defense (SLOD) gas tight seal</b>											
SLOD not included		0									
SLOD included		1									
<b>Enclosure</b>											
Single compartment enclosure		4									
<b>Type of protection</b>											
Non Ex - General purpose										A	
Intrinsically safe Ex ia / IS (Class I, II, III, Division 1) <sup>1)</sup>										B	
Non-incendive (Class I, Division 2) <sup>2)</sup>										D	
Dust Ignition proof, Ex t / DIP (Class II, Division 1) <sup>1)4)</sup>										M	
<b>Electrical connection</b>											
M20										F	
½" NPT										K	
<b>Local HMI</b>											
None, with blind lid		0									
Included, with blind lid		1									
Included, with window lid		3									

## Selection and ordering data (continued)

Selection and Ordering data	Order code
<b>Further designs</b> Please add "-Z" to Article No. and specify Order code(s).	
<b>Pressure Test Certificates</b>	
Pressure test certificate inspection certificate EN 10204-3.1 (AD2000-A4 / EN12266-1) <sup>8)</sup>	C01
Pressure test certificate inspection certificate EN 10204-3.1 (ASME B31.1 / B31.3) <sup>9)</sup>	C02
<b>Test certificates</b>	
Manufacturer's test certificate M to DIN 55350, Part 18 and to ISO 9000 - performance	C11
Inspection certificate EN 10204-3.1, material	C12
Inspection certificate EN 10204-3.1, material with NACE MRO175 and MRO103	C13
Test report EN 10204-2.2, material	C14
Test report EN 10204-3.1, PMI test - XRF (X-Ray Fluorescence)	C15
<b>Tagging</b>	
<b>Stainless steel tag [69 mm x 50 mm (2.71 x 1.97 inch)]</b>	
Tag (device parameters, max. 27 characters), plate, stainless steel 304/1.4301	Y15
<b>Regional Ex Approval</b> <sup>3)5)</sup>	
NEPSI (China)	E27
ATEX (Europe), IECEx (International), and UKEX (Great Britain)	E47
CSA (Canada) and FM (USA)	E48
ATEX (Europe), IECEx (International), UKEX (Great Britain), CSA (Canada), and FM (USA)	E49

- 1) Available only with one of -Z Regional hazardous Approval options.  
 2) Available only with -Z Regional Ex Approval option E48.  
 3) Not available with Type of Protection option A.  
 4) Available only with Second line of defense gas tight seal option 1.  
 5) Only one regional hazardous approval can be selected  
 8) Available only with Process connection type and material options KA ... KF, LA ... LE, and VA ... VE.  
 9) Available only with Process connection type and material options MA ... MF and NA ... NF.

Selection and Ordering data	Order code
<b>Operating instructions</b> All literature is available to download for free, in a range of languages, at <a href="http://www.siemens.com/processin-strumentation/">http://www.siemens.com/processin-strumentation/</a>	
<b>Accessories</b>	
Sun shield cover	A5E52107153
AW050 Bluetooth module kit, M20 (General purpose only)	A5E51857118

Selection and Ordering data	Order code
AW050 Bluetooth module kit, ½" NPT (General purpose only)	A5E52095588
Lightning Arrestor M20	7MF7903-7AB
Lightning Arrestor ½" NPT	7MF7903-7AC
SIMATIC RTU3010C compact, remote data manager with alarming	6NH3112-0BA00-0XX0
SIMATIC RTU3030C compact, remote data manager with alarming	6NH3112-3BA00-0XX0
Intrinsically Safe barrier	7NG4124-1AA00
SITRANS RD100, loop powered display	7ML5741-.....-
SITRANS RD150, remote digital display for 4 to 20 mA and HART devices	7ML5742-.....-
SITRANS RD200, universal input display with Modbus conversion	7ML5740-.....-
SITRANS RD300, dual line display with totalizer and linearization curve and Modbus conversion	7ML5744-.....-
SITRANS LT500, a versatile, single and multi-vessel level monitor/controller for virtually any application in a wide range of industries.	7ML60-.....-
For applicable back up point level switch - see point level measurement catalog	
<b>Spare parts</b>	
Electronic module, LR510, LR530, <DN80 / 3 inch, mA/HART	A5E53276263
Electronic module, LR530, LR550, LR580, >DN50 / 2 inch, mA/HART	A5E53276249
LR500 lid with window, Non-Exd/XP	A5E53276250
LR500 no window, Non-Exd/XP	A5E53276252
HMI graphical display, with interconnection cable	A5E53276247
Spring washers (x 40) kit for all process connection sizes	A5E53276258
Spring washers x 4, M10 and 3/8", stainless steel	A5E53308674
Spring washers x 4, ½", stainless steel	A5E53308675
Spring washers x 4, M12, stainless steel	A5E53308676
Spring washers x 8, M16 and 5/8", stainless steel	A5E53308677
Spring washers x 12, M20 and ¾", stainless steel	A5E53308678
Spring washers x 12, M24 and 7/8", stainless steel	A5E53308679

## Technical specifications

SITRANS LR530				
<b>Mode of operation</b> Recommended measuring range Note: Maximum measurement range depends on the flange size, refer to the table in dimension drawings.	<ul style="list-style-type: none"> <li>• DN 25: 20 m (66 ft)</li> <li>• DN 50, 2": 30 m (98 ft)</li> <li>• ≥DN 80, 3": 120 m (394 ft)</li> </ul>			
<b>Medium conditions</b> Process temperature  Process pressure	<ul style="list-style-type: none"> <li>• Standard version: -60 ... +150 °C (-76 ... +302 °F)</li> <li>• Thermal extension version: -196 ... +200 °C (-320 ... +392 °F)</li> </ul> Process connection and temperature dependent. See Pressure/Temperature curves for more information.			
<b>Design</b> Flange material Wetted materials • Antenna lens Process connections	316/316L stainless steel  PTFE lens with integral PTFE gasket  <table border="0"> <tr> <td style="vertical-align: top;"> <b><u>Raised face, Form B1, EN1092-1, DIN2501</u></b>  <ul style="list-style-type: none"> <li>• Flange DN25 PN6</li> <li>• Flange DN50 PN6</li> <li>• Flange DN50 PN6</li> <li>• Flange DN100 PN16</li> <li>• Flange DN150 PN16</li> <li>• Flange DN200 PN16</li> <li>• Flange DN25 PN40</li> <li>• Flange DN50 PN40</li> <li>• Flange DN80 PN40</li> <li>• Flange DN100 PN40</li> <li>• Flange DN150 PN40</li> </ul> </td> <td style="vertical-align: top;"> <b><u>Raised face, ASME B16.5</u></b>  <ul style="list-style-type: none"> <li>• Flange 1" 150lb</li> <li>• Flange 2" 150lb</li> <li>• Flange 3" 150lb</li> <li>• Flange 4" 150lb</li> <li>• Flange 6" 150lb</li> <li>• Flange 8" 150lb</li> <li>• Flange 1" 300lb</li> <li>• Flange 2" 300lb</li> <li>• Flange 3" 300lb</li> <li>• Flange 4" 300lb</li> <li>• Flange 6" 300lb</li> <li>• Flange 8" 300lb</li> </ul> </td> <td style="vertical-align: top;"> <b><u>Raised face, JIS</u></b>  <ul style="list-style-type: none"> <li>• Flange DN25 5K</li> <li>• Flange DN50 10K</li> <li>• Flange DN80 10K</li> <li>• Flange DN100 10K</li> <li>• Flange DN150 10K</li> </ul> </td> </tr> </table>	<b><u>Raised face, Form B1, EN1092-1, DIN2501</u></b> <ul style="list-style-type: none"> <li>• Flange DN25 PN6</li> <li>• Flange DN50 PN6</li> <li>• Flange DN50 PN6</li> <li>• Flange DN100 PN16</li> <li>• Flange DN150 PN16</li> <li>• Flange DN200 PN16</li> <li>• Flange DN25 PN40</li> <li>• Flange DN50 PN40</li> <li>• Flange DN80 PN40</li> <li>• Flange DN100 PN40</li> <li>• Flange DN150 PN40</li> </ul>	<b><u>Raised face, ASME B16.5</u></b> <ul style="list-style-type: none"> <li>• Flange 1" 150lb</li> <li>• Flange 2" 150lb</li> <li>• Flange 3" 150lb</li> <li>• Flange 4" 150lb</li> <li>• Flange 6" 150lb</li> <li>• Flange 8" 150lb</li> <li>• Flange 1" 300lb</li> <li>• Flange 2" 300lb</li> <li>• Flange 3" 300lb</li> <li>• Flange 4" 300lb</li> <li>• Flange 6" 300lb</li> <li>• Flange 8" 300lb</li> </ul>	<b><u>Raised face, JIS</u></b> <ul style="list-style-type: none"> <li>• Flange DN25 5K</li> <li>• Flange DN50 10K</li> <li>• Flange DN80 10K</li> <li>• Flange DN100 10K</li> <li>• Flange DN150 10K</li> </ul>
<b><u>Raised face, Form B1, EN1092-1, DIN2501</u></b> <ul style="list-style-type: none"> <li>• Flange DN25 PN6</li> <li>• Flange DN50 PN6</li> <li>• Flange DN50 PN6</li> <li>• Flange DN100 PN16</li> <li>• Flange DN150 PN16</li> <li>• Flange DN200 PN16</li> <li>• Flange DN25 PN40</li> <li>• Flange DN50 PN40</li> <li>• Flange DN80 PN40</li> <li>• Flange DN100 PN40</li> <li>• Flange DN150 PN40</li> </ul>	<b><u>Raised face, ASME B16.5</u></b> <ul style="list-style-type: none"> <li>• Flange 1" 150lb</li> <li>• Flange 2" 150lb</li> <li>• Flange 3" 150lb</li> <li>• Flange 4" 150lb</li> <li>• Flange 6" 150lb</li> <li>• Flange 8" 150lb</li> <li>• Flange 1" 300lb</li> <li>• Flange 2" 300lb</li> <li>• Flange 3" 300lb</li> <li>• Flange 4" 300lb</li> <li>• Flange 6" 300lb</li> <li>• Flange 8" 300lb</li> </ul>	<b><u>Raised face, JIS</u></b> <ul style="list-style-type: none"> <li>• Flange DN25 5K</li> <li>• Flange DN50 10K</li> <li>• Flange DN80 10K</li> <li>• Flange DN100 10K</li> <li>• Flange DN150 10K</li> </ul>		
Second line of defence option (SLOD)	Internal fused glass seal			



## Characteristic curves

SITRANS LR530 Flanged encapsulated antenna, EN 1092-1

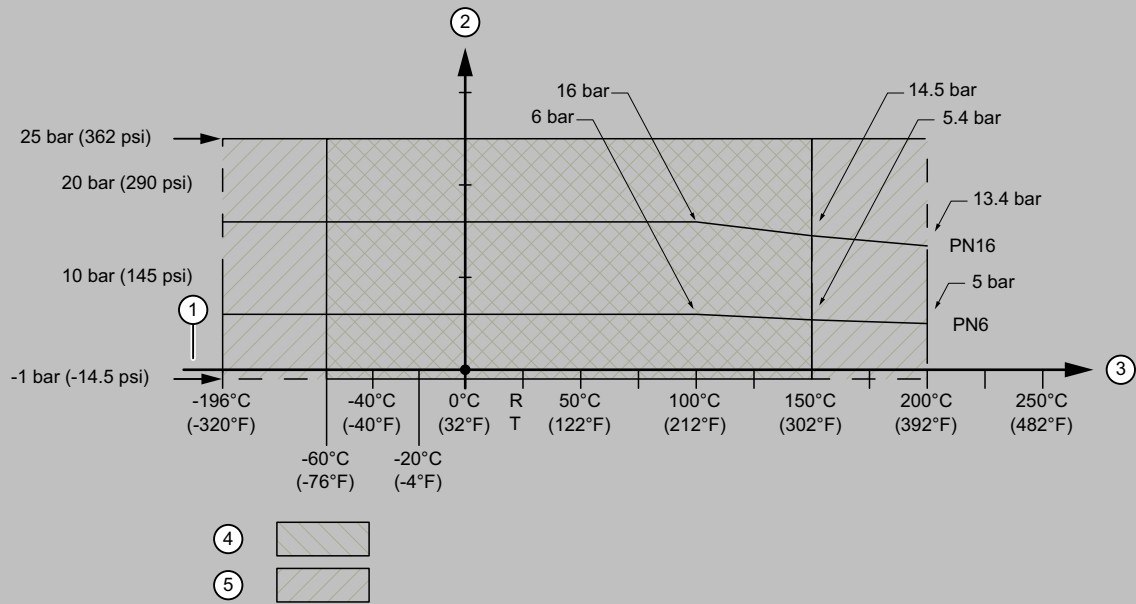

- ① Atmospheric pressure
- ② Allowable operating pressures
- ③ Allowable operating temperatures

- ④ PTFE without thermal extension
- ⑤ PTFE with thermal extension

Note: PN40 flange maximum allowable working pressure is 25 bar (362 psi).

SITRANS LR530 Flanged encapsulated antenna, process pressure/temperature derating curve, EN 1092-1

Characteristic curves (continued)

SITRANS LR530 Flanged encapsulated antenna, ASME B16.5

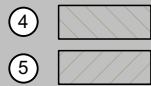
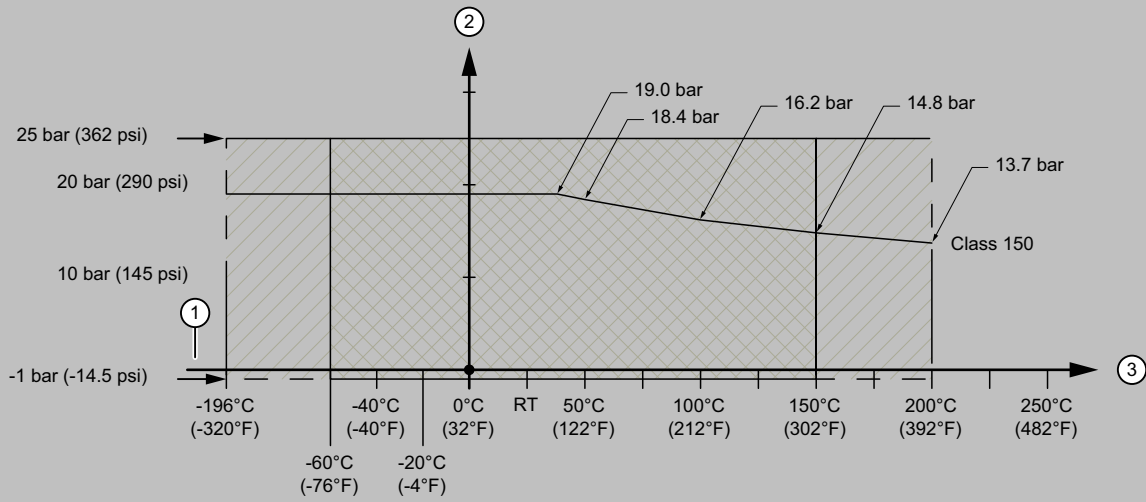

- ① Atmospheric pressure
- ② Allowable operating pressures
- ③ Allowable operating temperatures
- ④ PTFE without thermal extension
- ⑤ PTFE with thermal extension

Note: Class 300 flange maximum allowable working pressure is 25 bar (362 psi).

SITRANS LR530 Flanged encapsulated antenna, process pressure/temperature derating curve, ASME B16.5

Characteristic curves (continued)

SITRANS LR530 Flange encapsulated antenna, JIS B 2220

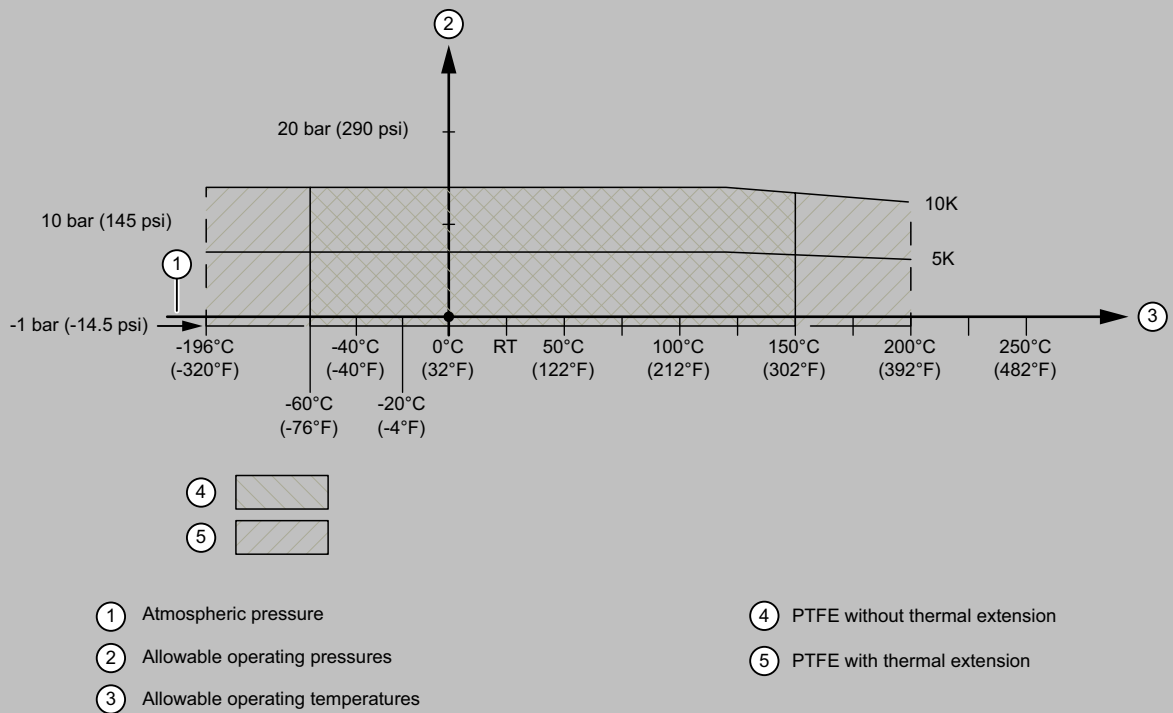

SITRANS LR530 Flanged encapsulated antenna, process pressure/temperature derating curve, JIS B 2220

## Dimensional drawings

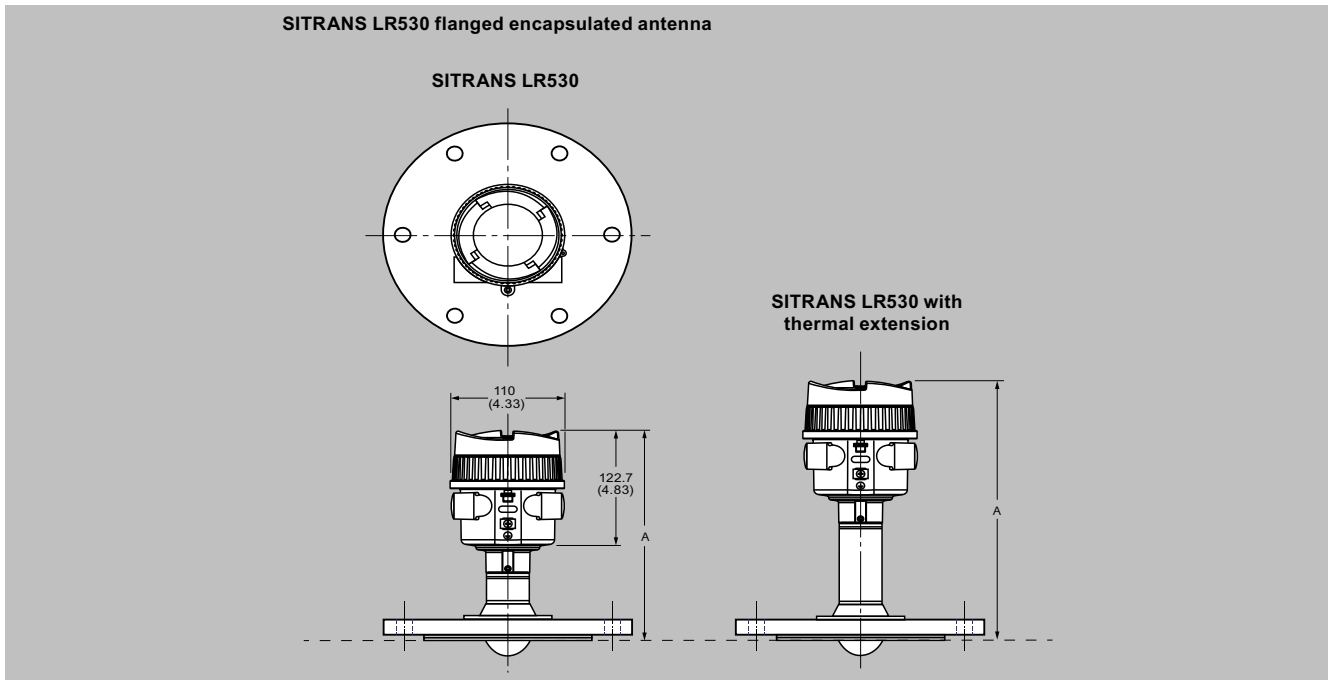

SITRANS LR530 Flanged encapsulated antenna, dimensions in mm (inch)

Process connection type	A mm (inch)	A with thermal extension	Beam angle	Recommended max. range [m (ft)]	Flange O.D. [mm (inch)]	Bolt hole circle Ø [mm (inch)]	Bolt hole Ø [mm (inch)]	No. of bolt holes	Flange thickness [mm (inch)]
Flange DN25 PN6, raised face, Form B1, EN1092-1, DIN2501 / 316/316L	201.7 (7.94)	221.7 (8.73)	10°	20 (65.6)	100 (3.94)	75 (2.95)	11 (0.43)	4	16 (0.63)
Flange DN50 PN6, raised face, Form B1, EN1092-1, DIN2501 / 316/316L	216.1 (8.51)	268.1 (10.56)	6°	30 (98.4)	140 (5.51)	110 (4.33)	14 (0.55)	4	20 (0.79)
Flange DN80 PN6, raised face, Form B1, EN1092-1, DIN2501 / 316/316L	243.2 (9.57)	295.2 (11.62)	3°	120 (393.7)	190 (7.48)	150 (5.91)	18 (0.71)	4	20 (0.79)
Flange DN100 PN16, raised face, Form B1, EN1092-1, DIN2501 / 316/316L	243.2 (9.57)	295.2 (11.62)	3°	120 (393.7)	220 (8.66)	180 (7.09)	18 (0.71)	8	20 (0.79)
Flange DN150 PN16, raised face, Form B1, EN1092-1, DIN2501 / 316/316L	243.2 (9.57)	295.2 (11.62)	3°	120 (393.7)	285 (11.22)	240 (9.45)	22 (0.87)	8	22 (0.87)
Flange DN200 PN16, raised face, Form B1, EN1092-1, DIN2501 / 316/316L	243.2 (9.57)	295.2 (11.62)	3°	120 (393.7)	340 (13.39)	295 (11.61)	22 (0.87)	12	24 (0.94)

Dimensional drawings (continued)

Process connection type	A mm (inch)	A with thermal extension	Beam angle	Recommended max. range [m (ft)]	Flange O.D. [mm (inch)]	Bolt hole circle Ø [mm (inch)]	Bolt hole Ø [mm (inch)]	No. of bolt holes	Flange thickness [mm (inch)]
Flange DN25 PN40, raised face, Form B1, EN1092-1, DIN2501 / 316/316L	201.7 (7.94)	221.7 (8.73)	10°	20 (65.6)	115 (4.53)	85 (3.35)	14 (0.55)	4	18 (0.71)
Flange DN50 PN40, raised face, Form B1, EN1092-1, DIN2501 / 316/316L	216.1 (8.51)	268.1 (10.56)	6°	30 (98.4)	165 (6.5)	125 (4.92)	18 (0.71)	4	20 (0.79)
Flange DN80 PN40, raised face, Form B1, EN1092-1, DIN2501 / 316/316L	243.2 (9.57)	295.2 (11.62)	3°	120 (393.7)	200 (7.87)	160 (6.3)	18 (0.71)	8	24 (0.94)
Flange DN100 PN40, raised face, Form B1, EN1092-1, DIN2501 / 316/316L	243.2 (9.57)	295.2 (11.62)	3°	120 (393.7)	235 (9.25)	190 (7.48)	22 (0.87)	8	24 (0.94)
Flange DN150 PN40, raised face, Form B1, EN1092-1, DIN2501 / 316/316L	243.2 (9.57)	295.2 (11.62)	3°	120 (393.7)	300 (11.81)	250 (9.84)	26 (1.02)	8	28 (1.1)
Flange 1" 150lb RF, ASME B16.5 / 316/316L	243.2 (9.57)	295.2 (11.62)	10°	20 (65.6)	108 (4.25)	79.2 (3.13)	15.7 (0.62)	4	16 (0.63)
Flange 2" 150lb RF, ASME B16.5 / 316/316L	216.1 (8.51)	268.1 (10.56)	6°	30 (98.4)	152.4 (6)	120.7 (4.75)	19.1 (0.75)	4	19.1 (0.75)
Flange 3" 150lb RF, ASME B16.5 / 316/316L	243.2 (9.57)	295.2 (11.62)	3°	120 (393.7)	190.5 (7.5)	152.4 (6)	19.1 (0.75)	4	23.9 (0.94)
Flange 4" 150lb RF, ASME B16.5 / 316/316L	243.2 (9.57)	295.2 (11.62)	3°	120 (393.7)	228.6 (9)	190.5 (7.5)	19.1 (0.75)	8	23.9 (0.94)
Flange 6" 150lb RF, ASME B16.5 / 316/316L	243.2 (9.57)	295.2 (11.62)	3°	120 (393.7)	279.4 (11)	241.3 (9.5)	22.4 (0.88)	8	25.4 (1)
Flange 8" 150lb RF, ASME B16.5 / 316/316L	243.2 (9.57)	295.2 (11.62)	3°	120 (393.7)	342.9 (13.5)	298.5 (11.75)	22.4 (0.88)	8	28.4 (1.12)
Flange 1" 300lb RF, ASME B16.5 / 316/316L	201.7 (7.94)	221.7 (8.73)	10°	20 (65.6)	124 (4.88)	88.9 (3.5)	19.1 (0.75)	4	17.5 (0.69)
Flange 2" 300lb RF, ASME B16.5 / 316/316L	216.1 (8.51)	268.1 (10.56)	6°	30 (98.4)	165.1 (6.5)	127 (5)	19.1 (0.75)	8	22.4 (0.88)
Flange 3" 300lb RF, ASME B16.5 / 316/316L	243.2 (9.57)	295.2 (11.62)	3°	120 (393.7)	209.5 (8.25)	168.1 (6.62)	22.4 (0.88)	8	28.4 (1.12)
Flange 4" 300lb RF, ASME B16.5 / 316/316L	243.2 (9.57)	295.2 (11.62)	3°	120 (393.7)	254 (10)	200.2 (7.88)	22.4 (0.88)	8	31.8 (1.25)
Flange 6" 300lb RF, ASME B16.5 / 316/316L	243.2 (9.57)	295.2 (11.62)	3°	120 (393.7)	317.5 (12.5)	269.7 (10.62)	22.5 (0.89)	12	36.6 (1.43)
Flange 8" 300lb RF, ASME B16.5 / 316/316L	243.2 (9.57)	295.2 (11.62)	3°	120 (393.7)	381 (15)	330.2 (13)	25.4 (1)	12	41.1 (1.63)

## Dimensional drawings (continued)

Process connection type	A mm (inch)	A with thermal extension	Beam angle	Recommended max. range [m (ft)]	Flange O.D. [mm (inch)]	Bolt hole circle Ø [mm (inch)]	Bolt hole Ø [mm (inch)]	No. of bolt holes	Flange thickness [mm (inch)]
Flange DN25 5K RF, JIS / 316/316L	201.7 (7.94)	221.7 (8.73)	10°	20 (65.6)	95 (3.74)	75 (2.95)	12 (0.47)	4	16 (0.63)
Flange DN50 10K RF, JIS / 316/316L	216.1 (8.51)	268.1 (10.56)	6°	30 (98.4)	155 (6.1)	120 (4.72)	19 (0.75)	4	20 (0.79)
Flange DN80 10K RF, JIS / 316/316L	243.2 (9.57)	295.2 (11.62)	3°	120 (393.7)	185 (7.28)	150 (5.91)	19 (0.75)	8	20 (0.79)
Flange DN100 10K RF, JIS / 316/316L	243.2 (9.57)	295.2 (11.62)	3°	120 (393.7)	210 (8.27)	175 (6.89)	19 (0.75)	8	20 (0.79)
Flange DN150 10K RF, JIS / 316/316L	243.2 (9.57)	295.2 (11.62)	3°	120 (393.7)	280 (11.02)	240 (9.45)	23 (0.91)	8	22 (0.87)