

## KNIFE GATE VALVE WITH DOUBLE ACTING PNEUMATIC ACTUATOR DUCTILE IRON BODY BETWEEN FLANGES PN10

### APPLICATION

The knife gate valve is particularly suitable for the most difficult applications.

**Area of use:** water treatment networks, pulp and paper industry, chemical plants, winemaking, cement works, pneumatic transport, storage.



**Fluids:** water, sewage, pulp, pasty products, powdery, granular, fibrous, abrasive and crystallizing.

### GENERAL CHARACTERISTICS

**Range:** from DN50 to DN1200.

- Knife Gate Valve on/off or regulation with rising stem.
- Molded monobloc body
- Unidirectional water tightness: Flow direction indicated on the body with an arrow.
- Installation between flanges ISO PN10.
- Small retention zone.
- Gate with a beveled cutting edge guided in the body with little backlash.
- Guaranteed closure, without risk of blockage.
- Standard polished gate, soft contact with the gaskets.
- Very resistant ductile iron packing flange avoids risks of breaks.
- Operating force reduced thanks to the elasticity of the gaskets.
- Pre-formed profiled sheet metal support plates from DN50 to DN300 for accessory or kit mounting.
- Full flow when fully opened, ensuring a high flow rate with low head loss.
- Flow regulation possible for pasty or abrasive fluids with installation of a deflector.



### STANDARDS

<b>Design</b>	Manufacture according to the requirements of the European directive n° 2014/68/UE «Equipment under pressure» : modulate H.					
	In option: product conform to European directive ATEX «ATmosphère EXplosive» n° 2014/34/UE.					
<b>Face to face</b>	Face to face dimension according to standard					
<b>Connection</b>	Mounting between flanges in accordance with EN1092-2 and DIN 2501 : ISO PN10					
<b>Tests</b>	Pressure test according to standards EN12266-1, DIN 3230, BS 5154 and ISO 5208.					
	DN	Body	Seat	DN	Body	Seat
	DN50-250 :	15 bar	11 bar	DN300-450:	10.5 bar	7.7 bar
DN500-600:	6 bar	4.4 bar	DN700-1200:	3 bar	2.2 bar	

### PRODUCT APPROVALS



EN 1092-2  
DIN 2501

## CONSTRUCTION

The valves are coated with epoxy paint to protect them against corrosion

Component	Coating
Body (1)	Epoxy powder RAL 6005 150 microns
Support plate (8)	Liquid epoxy RAL 6005 70 microns
Packing gland (7)	Liquid epoxy RAL 6005 70 microns

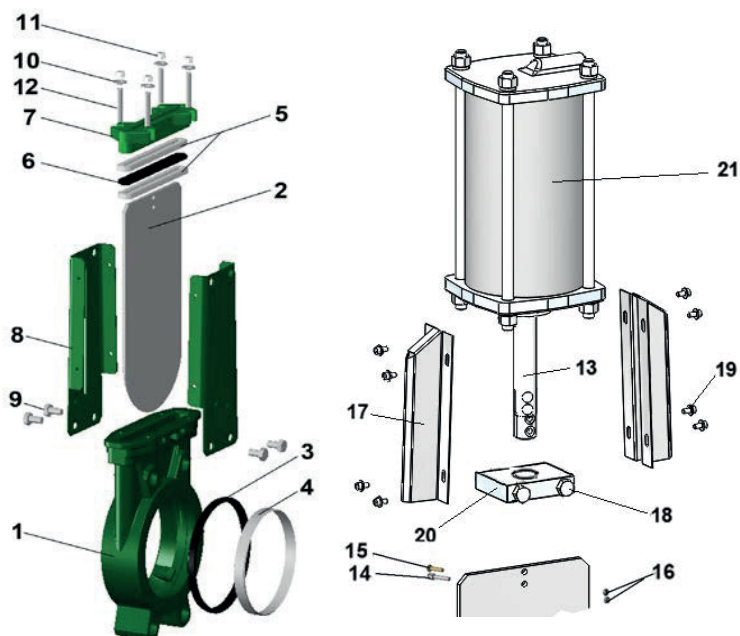

Pos.	Q-ty	Description	Material	Equivalences		
				DIN	ASTM	BS
1	1	Body	Ductile iron EN-GJS-500-7	GGG 50	A536 65-70-50-05	1563 EN-JS1050
2	1	Gate	Stainless steel X5CrNi 18-10	X5CrNi 18 10	A 182 AISI 304	1449-2 304 S15
3	1	Seat gasket (1)	NBR			NBR
4	1	Support ring (1)	Stainless steel X5CrNi 18-10	X5CrNi 18 10	A 182 AISI 304	1449-2 304 S15
5	2	Packing	PTFE			
6	1	O-Ring	NBR			NBR
7	1	Packing gland	Ductile iron EN-GJS-400-15	GGG 40	A536 65-45-12	1563 EN-JS1030
8	2	Support plate	Steel			
9	4*	Screw	Stainless steel A2-70			
10	4*	washer	Stainless steel A2-70			
11	4*	Nut	Stainless steel A2-70			
12	4*	Tie rod	Stainless steel A2-70			
13	1	Stem	Stainless steel 13% Cr	X12CR13	AISI 410	
14	1	Detection screw	Stainless steel X5CrNi 18-10	X5CrNi 18 10	A 182 AISI 304	1449-2 304 S15
15	1	Screw	Stainless steel A2-70			
16	2	Nut	Stainless steel X5CrNi 18-10	X5CrNi 18 10	A 182 AISI 304	1449-2 304 S15
17	1	Protection plate	Stainless steel X5CrNi 18-10	X5CrNi 18 10	A 182 AISI 304	1449-2 304 S15
18	4	Screw	Stainless steel A2-70			
19	1	Screw	Stainless steel A2-70			
20	1	Support nut	Zinc plated steel			
21	1	Pneumatic actuator	Aluminium			

\* - 8 for DN350-400; - 12 for DN450-900 and 16 for DN1000-1200 (1) - Parts missing on metal/metal sealing

## DIMENSIONS

DN		A	B	C	D	Ø F	Ø P	H	Weight (kg)
mm	inch								
50	2"	40	240	124	83	1/4"	80	412	7,5
65	2 1/2"	40	265	139	83	1/4"	80	458	7.8
80	3"	50	29*0	154	83	1/4"	80	502	8.4
100	4"	50	335	174	83	1/4"	100	562	12.5
125	5"	50	373	189	93	1/4"	125	642	16.4
150	6"	60	424	220	93	1/4"	125	718	20.5
200	8"	60	533	275	108	1/4"	160	882	35.8
250	10"	70	625	326	108	1/4"	200	1044	52
300	12"	70	732	380	108	1/4"	200	1164	72
350	14"	96	835	438	290	3/8"	250	1362	129
400	16"	100	945	494	290	3/8"	250	1542	144
450	18"	106	1040	547	290	3/8"	250	1677	177
500	20"	110	1150	613	290	1/2"	320	1815	268
600	24"	110	1354	716	290	1/2"	320	2130	351
700	28"	110	1540	835	320	1/2"	426	2488	556
800	32"	110	1750	972	320	1/2"	426	2798	679
900	36"	110	1990	1041	320	1/2"	538	3162	804
1000	40"	110	2195	1152	320	1/2"	538	3452	1053
1200	48"	150	2390	1255	400	1/2"	538	4048	-

Dimension A - face to face according to standard

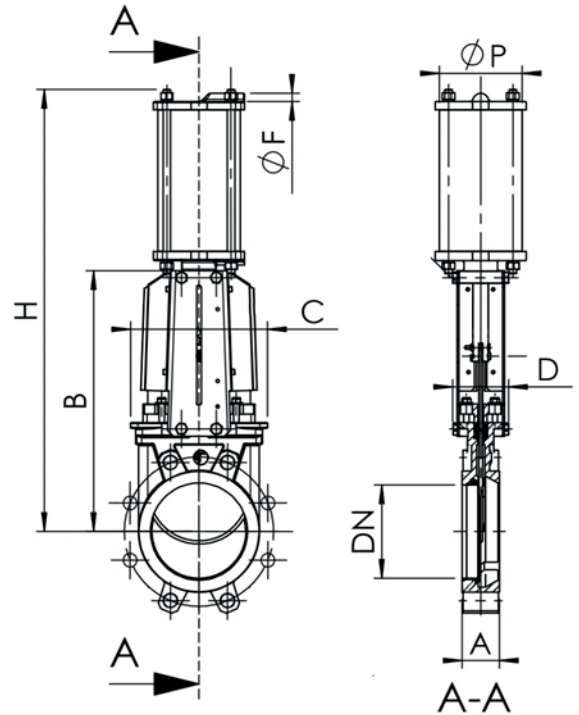

## MOUNTING

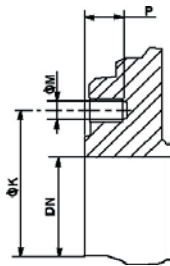
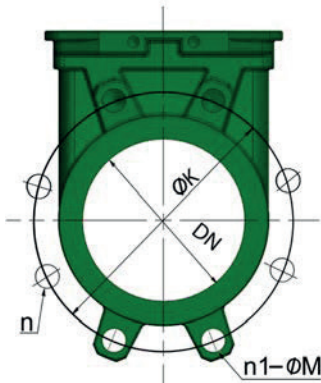

Body detail

DN		Maximum working (bar)	n	n <sub>1</sub> -ØM	P	ØK
mm	inch					
50	2"	10	4	4xM16	8	125
65	2 1/2"	10	4	4xM16	8	145
80	3"	10	8	4xM16	9	160
100	4"	10	8	4xM16	9	180
125	5"	10	8	4xM16	9	210
150	6"	10	8	4XM20	10	240
200	8"	10	8	4XM20	12	295
250	10"	10	12	8XM20	12	350
300	12"	7	12	8XM20	19	400
350	14"	7	16	10XM20	20	460
400	16"	7	16	10XM24	24	515
450	18"	7	20	14XM24	24	565
500	20"	4	20	14XM24	24	620
600	24"	4	20	14XM27	24	725
700	28"	2	24	16XM27	29	840
800	32"	2	24	16XM30	29	950
900	36"	2	28	20XM30	40	1050
1000	40"	2	28	20XM33	40	1160
1200	48"	2	32	24XM36	40	1380

n- total number of holes

n<sub>1</sub>- number of threaded holes

## WORKING CONDITIONS

Maximum working pressure: DN50-250 : 10 bar  
 DN 300-450 : 7 bar  
 DN500-600 : 4 bar  
 DN700-1200 : 2 bar

Maximum working temperature : -10°C / +80°C (standard tightness)

▲ The above mentioned pressures are only valid if the direction of assembly indicated by the arrow on the valves is observed.

### Upstream/downstream tightness



Elastomer tightness

Metal/metal tightness

### Packing tightness

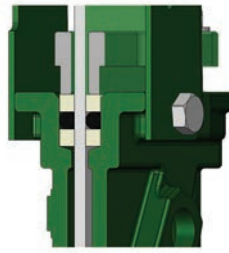

PTFE/Elastomer

### Tightness in option

Tightness	maximum temperature
Metal/metal	Tmax : -10°C / +80°C
White NBR	Tmax : -10°C / +80°C
EPDM	Tmax : -10°C / +130°C
Silicone	Tmax : -10°C / +170°C
FPM (Type Viton®)	Tmax : -10°C / +170°C
PTFE	Tmax : +4°C / +170°C
CSM (Type Hypalon®)	Tmax : +4°C / +80°C

▲ To ensure a satisfactory tightness, when using the PTFE gasket, the operating pressure must be at least 1 bar.

### Flow rates of valves under different differential pressure (m<sup>3</sup>/h)

DN		0.2 bar	0.4 bar	0.6 bar	0.8 bar	1.0 bar
mm	inch					
50	2"	93	134	165	185	206
65	2 1/2"	129	180	213	268	309
80	3"	191	309	371	422	494
100	4"	443	618	721	824	927
125	5"	700	927	1133	1339	1545
150	6"	927	1339	1545	1906	2060
200	8"	1597	2369	2987	3399	4017
250	10"	2472	3502	4429	5150	5665
300	12"	4120	5665	6798	7828	8755
350	14"	5335	7372	8730	9700	11640
400	16"	6693	9312	11640	13580	15520
450	18"	8342	12610	14550	16490	18430
500	20"	9700	14550	17460	19400	22310
600	24"	14550	19400	25220	29100	33950
700	28"	17460	29100	36860	42680	48500
800	32"	25220	38800	48500	52380	58200
900	36"	34920	50440	61110	67900	77600
1000	40"	46560	62080	77600	87300	97000
1200	48"	62080	87300	106700	121250	145500

The column of the table under 1 bar gives the values of the Kvs of the valves.